



DIAGNOSTIC EQUIPMENT

Comprehensive safety systems

Equipment for the police





ABOUT THE COMPANY

For 25 years the scientific-production company 'META' has successfully operated on the Russian market of automotive diagnostic equipment and specialised road safety equipment. META's work is primarily focussed on the development and production of modern hi-tech based diagnostic equipment.

META started its operations in 1988, in Tashkent, where tasked by the Chief Road Traffic Inspectorate (GAI USSR) the company developed its first environmental monitoring device — a portable smoke meter META-01. This compact and convenient instrument instantly became popular with Chief Traffic Inspectorate (CTI) and Goskomekologia (State Committee for the Environment). The next pioneering development created by META was the spectrophotometric breathalyser AKPE-01META, which is still in use and remains the only device used in Russia to test alcoholic intoxication. In the course of 15 years the Company started mass of three popular breathalyser models, including the smallest spectrographic breathalyser with an autonomous power supply: AKPE-01M, which is being supplied in the RF for 4 years now to units of DPS (Road traffic service) of the State automotive inspectorate (SAI). At present META is a scientific-production association of enterprises producing instruments, scientific-technical and study centres, design offices and diagnostic stations. Company's production programme covers a wide range of diagnostic equipment for State MOT and vehicle servicing, environmental monitoring devices, specialised equipment for the Russian Ministry of Internal Affairs and MoD, electronic personnel and vehicle monitoring devices, as well as comprehensive security systems for various facilities. All serially produced systems and instruments were developed on the basis of technical tasks of the Ministry of Internal Affairs and MoD, and are successfully used to ensure transport safety at military and civilian facilities in the RF and CIS. META products were awarded gold medals and diplomas at prestigious international exhibitions and by quality programmes. In 2007, META was the winner of the All-Russian Competition 'Safe roads' in the nomination 'Best technical diagnostics devices for automotive transport' and in the nomination 'Best device for testing drivers for alcohol intoxication level (breathalyser)'. Meta's plants for instrument production are equipped with modern automated surface assembly line for electronic components, high-precision machines for die and mould manufacturing, hi-tech lines



for the manufacture of optical components and power-measuring sensors, quality control instruments, including RX- soldering control for chip components which ensured improvements in quality and volume of production. At all development and production stages META uses a comprehensive QM system in compliance with international standards ISO 9001-2001/ISO 9001-2000 and GOST RV 15.002-2003. Over 4000 MOT technical inspection and service facilities in Russia and CIS are equipped with instruments and stands produced by META; over 200 000 measurement devices with the name META are used to monitor environmental parameters in transport and for the evaluation of vehicles' technical condition according to road safety requirements in Russia and CIS. META products are successfully used in technical centres of various companies and service stations for Russian and foreign vehicles, such as VAZ, KAMAZ, BMW, HYUNDAI, RENAULT, KIA.

Fast developing network of regional service centres META-SERVICE and technical inspection stations of our subsidiary: 'Russian technical road safety centre' demonstrate the quality and effectiveness of our equipment.

A wide network of META service centres in RF and CIS is equipped by standard models of testing plant, repair documentation and test beds. Multilevel training system for managers and service engineers, learning centres in Almata, Orel, Moscow, Zhigulevsk, Novosibirsk, and Irkutsk, annual seminars and conferences devoted to new designs, service support and software updates enable us to build a successful business not only through sales of META produced equipment but also by servicing it and provision metrology services for working devices and appliances. META values mutually beneficial cooperation and offers a flexible system of discounts and payment instalments for its equipment, as well as providing equipment as credit against goods.

A wide-ranging production programme and on-going product updates based on the latest world achievements in technology guarantee effective projects and fast investment repayment.



COMPANY'S NEW PRODUCTION PROGRAMME FOR 2013-2014

- Container and block technical inspection stations with axle load of up to 15t. based on mobile CTM 15000U.01M bed with play detector LD – 16000;
- Mobile technical inspection stations in a trailer based on low-profile brake test stands with axle load of from 3 to 13 t.;
- Trailer loader for braking system testing;
- Mobile office units in trailers and quickly erected modular capsule type buildings;
- Automated vehicle testing tracks for driver training, with markings detection and navigation system GLONASS;
- Low-profile block roller braking testing stands, with axle load of up to 16 t. applied to cars;
- Suspension and shock absorbers test stands;
- Video Highway Code registration systems for pedestrian crossings;
- Automated weight-control posts based portable scales VA-D for weighing vehicles when moving and stationary;
- Transport vehicles monitoring system based on satellite navigation GLONASS with safety parameters on-board control function during transportation of special goods and special military units;
- Driver's intoxication level monitoring system ALCOZAMOK with GLONASS trackers;
- Automated systems of personnel and health monitoring of persons controlled by TALISMAN.
- Novelty of 2013! Low-profile portable scales for control vehicle weighing VA-15S-2 and VA-15S-2M

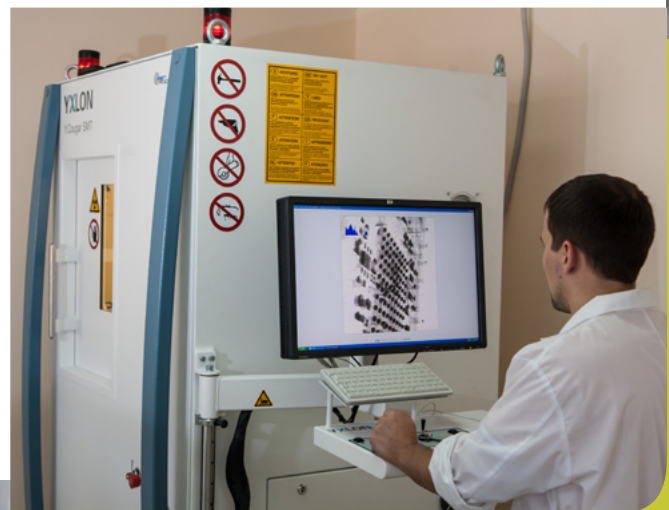

CONTENTS



About the company 3

Automated technical control lines 8

Stationary lines for technical inspection LTK-S-META	18
Mobile container and block technical control lines LTK-M-META, LTK-MB-META	24
Travelling technical control points for vehicles based on GAZ 2705 or Ford transit LTK-P	32
Video-registration systems during vehicle technical inspection	38

Diagnostic equipment 41

Universal brake testing stands STM	42
Lateral wheel slip tester	46
Chock absorbers test stand SPP 2500	47
Remote control panel PDU-META	48
Dynamic power roller stands SDM	49
Multi-component gas analyser AUTOTEST	52
Измеритель эффективности тормозных систем ЭФФЕКТ-02	56
Exhaust gases smoke opacity meter META-01 MP	58
Meters of vehicle lamps light parameters IPF	60
Measuring angle of turning transducers ISL-M	62
Play-detectors LD-4000, LD 4000P, LD 4000P, LD-8000, LD-16000, LD 16000P, LD 16000R	64
Light transmission (permeability) meter for window glass TONIC	66
Leak detector TTs-META	68
Software-hardware unit LTK	70
Break controls testing kits M-100 and M-100-02	70
Vehicle lamp tester TF-01	71
Markings on assemblies and units detector Detector NM	72
Fluid pollution indicator IZZh-M	73

Weight measuring equipment 75

Travelling weight control post PPVK	76
Vehicle scales, portable VA-15S	77
Vehicle scales to weigh during motion VA-D	79
Platform-type scales VPA	83



Special safety equipment

87

Comprehensive safety systems Barrier	88
Anti-drunk vehicle ignition lock system	92
Radar speed meters with video-recording AUTOSCAN	94
Ethanol vapour concentration analysers in exhaled air AKPE-01.01; AKPE-01.01	96
Ethanol indicators in exhaled air ALKOTESTER	100
Hardware-software audio and video observation unit for training and for driving examiners in practical and qualification driving licence tests EKSPERT-M.4	102
Hardware-software audio and video observation unit for traffic monitoring EKSPERT-M.2	104
'Intelligent' system for driver training and for qualifications tests AVTODROM-META	106

Metrological equipment

111

Air-alcohol mixture generators GSVS-META-02	112
Universal calibration panel	112
Angle measuring apparatus 3-rd class SPL-META	113
Weight measuring unit UVS	113
Standard telecentric lighting unit ETO-2	114

New production programme

115

Electronic monitoring system for personnel and access control TALISMAN	115
Vehicle monitoring system 'GEOTRANS'	117
Global goods movement monitoring system in space METKA	118
Integrated safety systems	119

Awards and achievements

120

Russian technical road safety centre

122

Service centres

126

VEHICLE TECHNICAL INSPECTION STATIONS

based on stationary, mobile and travelling
technical monitoring lines
LTK-S, LTK-M, LTK-P



Turn-key station construction: design, supply, installation, technical servicing.
Professional training for controllers and experts of State MOT.
Licence of the Russian Ministry of Education RO 012121 reg. N 2763 dated 25.02.11

Automated technical control lines produced by META provide the most complete set of measuring instruments and diagnostic stands for technical inspection stations and posts from one developer-manufacturer. Software-hardware unit 'Diagnostic control' ensures automatic wireless transmission of evaluation results of vehicle technical condition as measurement protocols, identified using registration marks which are input from the panel of each instrument. This enables to set up a multi-post diagnostics arrangement and increase five-fold line throughput. META offers automated technical control lines LTK RK with wireless connection of all the instruments to a PC via a radio communication channel. LTK RK offers a significant reduction in line assembly cost, enhances equipment reliability and operational service life. The area of assured reception is up to 300 m.

Completely new performance enhancing possibilities are provided by the video-registration system 'M-VIDEO', designed to automate the procedure of technical inspection using technical diagnostic means on stationary, travelling and mobile technical inspection stations. A video image of the vehicle permits on the basis of an automatically recognised registration mark to find information about the vehicle, his/ her owner, in the traffic police data bases, and excludes technical inspection without the vehicle being present.



A photographic image of the vehicle indicating date and time, registration data and inspection results of vehicle's condition are recorded on a diagnostic card and kept until the next inspection.

Combined remote control panel PDU-Meta from the LTK kit performs two functions: remote control of brake testing stand operation and electronic results registration of vehicle's parameters visual assessment and automatic data transmission to a central computer via a radio channel.

META offers acquisition of its diagnostic equipment by instalments, long-term credit and leasing.

Owners of technical service stations and sites suitable for setting up technical inspection stations may count on creating a JV, with META providing its equipment.

LTK modifications:

LTK-S

full diagnostic kit including instruments and brake test stands to check the technical condition of passenger cars and minibuses.

LTK-M

mobile container diagnostic station, dimensions 6040 x2450 x2700 mm with hydraulic drive for lifting ramps with a car and a heated office 7,2 m2, to check the technical condition of mini-buses and mini-lorries.

LTK-P

travelling technical inspection post based on GAZ 2705 or Ford Transit. The best solution for inspection in remote areas.





Functions:

- Inspection for compliance with GOST R 51709-2001 and 'Technical safety regulations for wheeled vehicles' during technical inspection, service and repair.
- A multi-post technical inspection line may be set up which increases throughput five-fold.
- Automatic data transfer to PC via line communication or by radio.
- Display of established template for diagnostic card.
- Car video-registration with registration mark recognition and automatic data transfer to PC.

'Diagnostic control' software enables:

- Networking of several LTK lines with a common entry into data base.
- Connection and data exchange among registration, search and 'Dynamic control' software bases.
- Filling in or print-out of ready diagnostic card blanks with field and form correction at customer's request.
- Automatic registration of vehicle test at the station and creation of reporting on fault types.
- Registration of payment for technical inspection and issue of technical coupons with relevant reports.
- Video-monitoring and photographic registration of vehicle external appearance, automatic recognition of registration mark, request and receipt of data on the vehicle, his/he owner for data base.
- Station audit – automatically filled in operations journal, indicating date, time and actions completed.





DIAGNOSTIC EQUIPMENT KIT LTK

IN ACCORDANCE WITH THE ORDER OF MINPROMTORG (MINISTRY OF COMMERCE AND INDUSTRY) OF 6 DECEMBER 2011 NO. 1677 'ON APPROVAL OF KEY TECHNICAL FEATURES OF DIAGNOSTIC EQUIPMENT AND ITS LIST' INCLUDES:

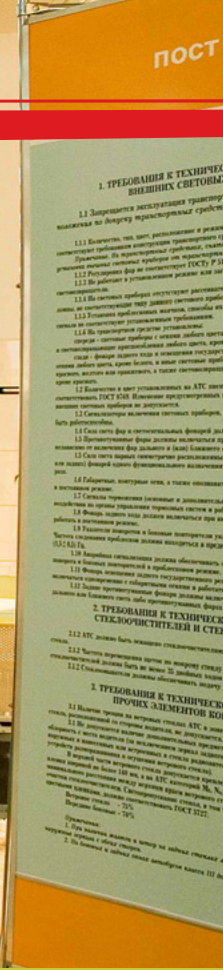

Various modifications of universal brake test stands STM for vehicle diagnostics with axle load weight from 1.5 to 18t. Universal brake test stands STM may be equipped with wheel slip tester and shock absorbers stand providing a comprehensive diagnostic line which will fully comply with the requirements of leading vehicle manufacturers.



Smoke opacity meter of exhaust gases **META-01 МП 0.1**



Vehicle lamps light parameter meter **IPF-01**



Brake systems efficiency meter using road test method **EFFEKT**



Multi-component gas analyser to measure CO, CO₂, CH, O₂, NO_x concentrations, crankshaft rotation frequency during vehicle exhaust gases toxicity test **AUTOTEST**



Summary steering play meter **ISL-M**



Light transmission meter for tinted and obscured windcreens **TONIK**



Remote control pane **PDU-META**



Instrument for checking braking system hydraulic drive sealing **M 100**



Instrument for checking markings of assemblies and units **DETEKTOR NM**



Leak detector to check gas system sealing **TTS-META**



Play detector **LD-4000, LD-4000П, LD-8000, LD-16000, LD-16000P**









Stationary
technical control lines
LTK-S



Stationary lines for vehicle technical control LTK-S provide compactly laid-out diagnostic equipment and brake test stands on the floor or in a pit at customer's industrial sites at ambient temp. from -10°C to +40°C.

If this line is in unheated premises it is recommended to install in addition a heated office block for operators, dimensions no less than 3000x2400x2600 mm.

Multi-post arrangement of technical control considerably increases line throughput. Recommended dimensions of industrial premises for 4-post passenger car technical control line based on brake test stands STM-3000M.01 and STM 3000M.02 equals 5x18 m., based on brake test stands STM-10000, STM 13000.01 and STM 13000.02, STM 16000.01, STM 16000.02 and STM 18000 – 7.5 x13.9 m.; its throughput is 20000 cars per annum. To increase its throughput to 30 000 cars we are offering an efficient dual-beam arrangement with seven testing posts on an area of 12 x 24 m.





META OFFERS:

3 types of stationary technical control lines LTK-S

for passenger cars and minibuses

6 types of stationary technical control lines LTK-S

for passenger cars and lorries depending on brake test stands equipment



LTK-S 3500 M — technical control line to test the condition of passenger cars and minibuses, including with a full drive and axle load up to 3500 kg.

LTK-S 3000M.01 — automated universal technical control line to test technical condition of passenger cars and minibuses, including a full drive, and axle load weight up to 3000 kg. LTK-S 3000M.01 includes a single block, low-profile brake test stand STM 3000M.01, weighing only 360 kg and not requiring building and assembly work to be installed.

LTK-S 3000M.02 — automated universal technical control line to test the condition of passenger cars and minibuses, including full drive, and axle load up to 3000 kg. LTK-S 3000M.02 includes a low-profile brake test stand STM 3000M.02, comprising 2 blocks, each weighing 170 kg, and doesn't require building and assembly work to be installed. Thanks to its low weigh the stand is easily moved and enables quick rolling-out of the technical control line on any site.



LTK-S 10000 — automated universal technical control line to test the condition of passenger cars and lorries as well as minibuses with axle load up to 10000 kg.

LTK-S 13000.01 — automated universal technical control line to test the condition of passenger cars and lorries as well as minibuses with axle load up to 13000 kg. LTK-S 13000M.01 includes a single-block, low-profile brake test stand STM 13000M.01; roller stand weight – 1150 kg. Increased dimensions of the roller unit increase equipment service life thanks to wear resistance of brake test stand rollers.

LTK-S 13000.02 — automated universal technical control line to test the condition of passenger cars and lorries as well as minibuses with axle load up to 13000 kg. LTK-S 13000M.02 includes a brake test stand STM 13000M.02, comprising 2 blocks, each weighing 455 kg. Increased dimensions of the roller unit increases equipment service life thanks to wear resistance of the brake test stand rollers.

LTK-S 16000.01 — automated universal technical control line to test the condition of passenger cars and heavy-duty lorries as well as buses of any category, with axle load up to 16000 kg. LTK-S 16000M.01 includes a single block brake test stand STM 16000M.01, weighing 945 kg.

LTK-S 16000.02 — automated universal technical control line to test the condition of passenger cars and heavy-duty lorries, as well as buses of any category, with axle load up to 1000 kg. LTK-S 16000M.02 includes a brake test stand STM 16000M.02, comprising two blocks each weighing 600 kg

LTK-S 18000 — automated universal technical control line to test the condition of passenger cars and heavy-duty lorries, as well as buses of any category, with axle load up to 18000 kg.

Control post with single and dual beam LTK-S arrangement SCHEME

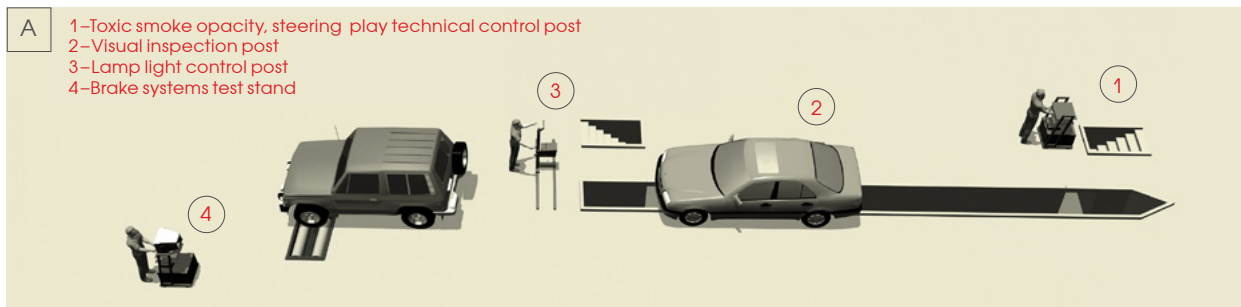

Dimensions of area occupied 5x18m
 Station throughput – 20000 cars per annum

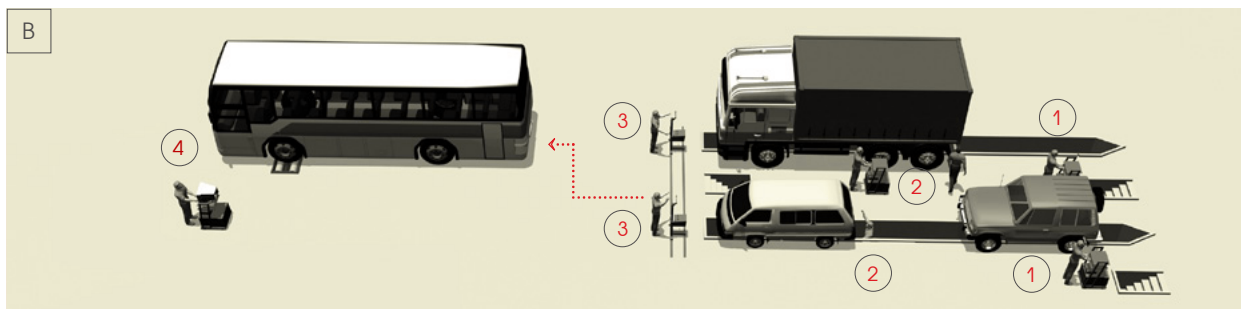

Dimensions of area occupied 12x24m
 Station throughput – 30000 cars per annum

Advantages:

- Several technical control lines with compact lay-out and LTK network with a single entry into a common data base.
- Savings in resources and high efficiency thanks to a reasonable price and high throughput.
- Complete supply and line installation.
- Multi-post inspection technology with simultaneous data transmission from online diagnostic instruments to the central computer.
- Fully automated technical inspection process using diagnostic equipment ensuring high line throughput, inspection objectivity and high measurement precision.
- Convenient to use STM remote control radio panel and visual inspection easy to use .



TECHNICAL CONTROL LINES BASED ON LOW-PROFILE STANDS, DO NOT REQUIRE CONSTRUCTION AND ASSEMBLY, TURNKEY PRICE STARTING FROM 800 000 ROUBLES.

Mobile container and block
technical control lines
LTK-M, LTK-MB





Mobile container and block technical control lines LTK-M and LTK-MB designed to check passenger cars, mini-buses and mini-lorries technical condition, with axle load of up to 3500 kg, 10000 kg, 13000 kg, 16000 kg and 18000 kg. Economical and effective solution which does not require capital expenditure for diagnostic centre construction. Main advantage – fast rolling out. On a rigid framework of a standard container are installed: brake test stand, office block, foldable trestle with hydraulic drive and a full kit of diagnostic instruments equipped with data transmission channels and power supply. The line is equipped with comfortable furniture, power consumption meter and fire extinguishers.

Line setting-up at a new site does not require special site preparation and equipment adjustment. Foldable trestle measuring 3x15 m is equipped with regulated feet for horizontal alignment on the site and is corrosion protected by a zinc coating and solid polymer paint.

To expand the covered working area light knock-down awning made from profiled sheet with typical dimensions of 6000x6000x4500mm and 9000x6000x4500mm are offered.

META offers two types of mobile technical control lines: container and block.



MOBILE CONTAINER TECHNICAL CONTROL LINE **LTK-M (MSD)**

META offers 4 types of mobile container lines depending on the brake test stand installed

Made as a single block metal container (6040x2440x2600 mm) with a rigid frame which serves as a base where the office block and work section with the brake test stand installed and fixed are located. The work section is equipped with opening ramps which are activated by hydraulic drives and are used to create a horizontal area and for vehicles to drive onto the brake test stand.



MSD-10000, MSD-13000, MSD-16000 to check the technical condition of all types of vehicles with axle load of up to 10000 kg, 13000 kg, 16000 kg, including passenger cars, vehicles with full drive, lorries and buses. Universal container station with an opening roof is designed for checking any vehicle categories without height limit and with axle load up to 10000 kg, 13000, 16000 kg. When testing passenger cars and minibuses whose height is 2.5 m the roof of the working section is closed and provides a reliable protection from precipitation.

If necessary the roof opens using a hydraulic drive controlled by an operator from the panel in the office section.



MSD-3500 — universal container station to check technical condition of passenger cars, min-buses and mini-lorries with axle load of up to 3500 kg



MOBILE BLOCK TECHNICAL CONTROL LINE **LTK-MB**

META offers 5 types of block lines, depending on the brake test stand installed

Made as two separate blocks: mobile office: (dimensions 2400x3500 mm) and roller unit of the brake test stand. Brake stand ramps are supplied as individual section and are assembled in the place where they will be used (hydraulic drive not supplied). Height without covering tent is not limited.

LTK-MB 10000, LTK-MB 13000, LTK-MB 16000, LTK-MB 18000 — are intended to check the technical condition of all types of vehicles with axle load of up to 10000 kg, 13000 kg, 16000 kg, and 18 000 kg, including passenger cars, vehicles with full drive, lorries and buses.



LTK-MB 3500 — is designed to check the technical condition of all types of vehicles with axle load of up to 3.5 t.

NEW IN 2013!

Block stations with manual drive for trestle opening, load carrying capacity 3500 kg, 10000 kg, 13000 kg, 16000 kg.

TECHNICAL SPECIFICATIONS		
DESIGNATION	LTK-M (MSD-3500)	LTK-MB 3500
	Mobile, container diagnostic station with opening roof (lifting roof)	Mobile block diagnostic station
Axle weight load, t	3.5	3.5
Basic brake test stand	STM-3500M	STM-3500M
Track width, mm	770-2210	770-2210
Area occupied when set up, m	11x6,1	16x6.8
Height of tested vehicles, m	no limit	no limit
Types of vehicles tested	passenger cars, lorries Minibuses, trailers and semi-trailers	
Container dimensions, mm	6040x2600x2440	-
Office block dimensions, mm	-	3000x2400x2600
Additional metal awning, mm	-	6000x8000x5100

Advantages of mobile technical control lines LTK-M and LTK-MB:

- can be used on any horizontal site with asphalt-concrete or gravel covering;
- can be used with brake test stands: STM 3500 M, STM 10000, STM 13000.01, STM 13000.02, STM 16000.01 and STM 16000.02, STM 18000
- has a comfortable office block for operators and traffic inspector, as well as for diagnostic equipment, PC, printer, cabinet for documentation and power unit for the brake test stand;
- are installed on open sites and do not require specially adapted heated premises;
- minimal expenditure for line installation and maintenance;
- STM remote control radio console and visual inspection.

TECHNICAL SPECIFICATIONS		
НАИМЕНОВАНИЕ	LTK-M (MSD-10000) LTK-M (MSD-13000) LTK-M (MSD-16000)	LTK-MB 10000 LTK-MB 13000 LTK-MB 16000 LTK-MB 18000
	Mobile, container diagnostic station with opening roof (lifting roof)	Mobile block diagnostic station
Axle load, kg	Depending on STM type:	В зависимости от типа СТМ: 10000 кг, 13000 кг, 16000 кг
Basic brake test stand	As per order:	По заказу СТМ-10000 СТМ 13000.01 СТМ 13000.02 СТМ 16000.01 СТМ 16000.02
Track width, mm	960-2800	960-2800
Area occupied when set up, m	16x6,8	16x6,8
Height of tested vehicles, m	No limit	No limit
Types of vehicles tested	Passenger cars, lorries buses	Passenger cars, lorries buses
Container dimensions, mm	6040x2450x2700	-
Office block dimensions, mm	-	3000x2400x2600
Additional metal canopy, mm	-	6000x8000x5100



DUAL USE DIAGNOSTIC EQUIPMENT

META — supplier of diagnostic equipment for the Russian MoD since 1997



SELF-UNLOADING MOBILE UNIT FOR TECHNICAL CONTROL AND REPAIRS OF MILITARY AUTOMOTIVE EQUIPMENT MKTKR

Designed to assess residual life and repair of military automotive equipment in the field. MKTKR unit is made in two transportable containers.



Composition of self-loading container MKTKR:

- office block;
- control and measurement equipment;
- brake test stand STM 10000;
- hardware-software unit «Diagnostic centre of military automotive hardware».

All MKTKR instruments are combined via radio communication channel with the diagnostic centre and on board information memory store.

ON BOARD DATA MEMORY STORAGE (ODMS) — VEHICLE ‘BLACK BOX’.

Designed to store data on technical condition of vehicles and its transmission via GSM channel to the terminal.

ODMS monitors movement of vehicles, their identification based on registration no. in order to monitor and manage their movement. During technical control ODMS registers in memory technical condition parameters of vehicles, route set in the task as files with date, time and vehicle identification parameters.

ODMS determines vehicle location using GLONASS/GPS, saves data on the route covered.

Functions:

- Uninterrupted registration in automatic mode of movement parameters and technical condition
 - speed of movement;
 - driver’s work and rest periods;
 - information on fuel consumption and fuel top-up;
 - coolant and engine oil temp.;
 - number of engine crankshaft revolutions;
 - change of on board power supply parameters during travel and stops.
- Periodic definition of absolute coordinates.
- Storing information in flash-memory linked to date and time.
- Wireless information reading from flash memory to computer terminal.
- Automatic identification of vehicle registration no.
- Remote control of routes set out in tasks and technical condition of military vehicle.

SPECIFICATIONS	
Power supply, on board mains TC, B	9-36
TRANSCIVER:	
Max. transceiver output power, MWt	1.1
Operational frequency range, MHz	2400-2483.5
Number of communication channels in frequency ranger	16
Modulation type	DSSS
Speed of radio data transmission (via channel), BIT/SEC.	250000
Volume of flash memory, Mbit	64
Range of operational temp., °C	From -40 to + 85

Transportable technical
control points for vehicles
based on GAZ 2705 or Ford Transit.

LTK-P (PPTK TS)



TRAVELLING TECHNICAL CONTROL POINT PPTK TS

It's the optimal solution for technical inspection travelling out to remote locations with a small number of vehicles. Own on board mains for diagnostic equipment and office appliances, a comfortable 'office on wheels' with two work stations, compact and safe instrument packing arrangement in travel mode ensures total autonomy and high mobility of the technical control point.

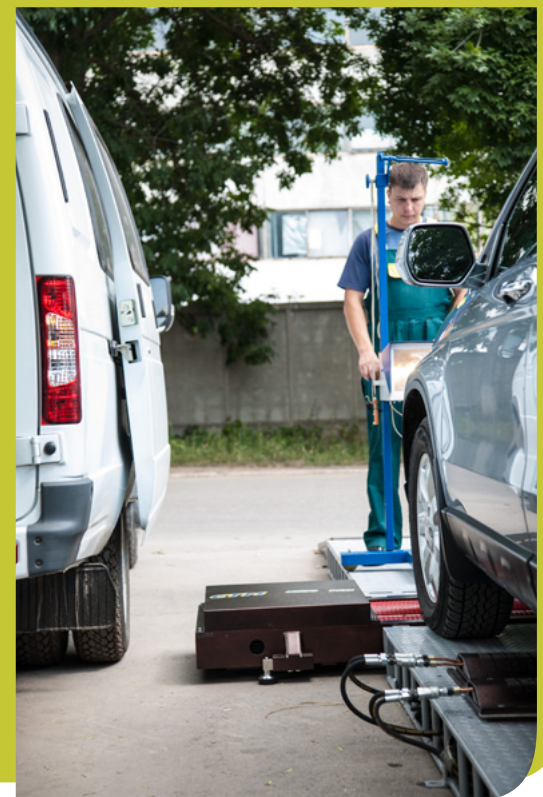



The work compartment of PPTK TS comprises:

Work place for traffic inspector, work table with a table lamp, safe for important documents and special goods, pull-out document drawers, sockets to connect equipment, rotating chair.

Operator-controller work station: work table, rotating chair, PC Notebook, printer, heater, fire extinguisher, first aid box and a locker for equipment and office equipment transport.





PPK TS comprises:

Portable rack for instruments and their connection to LTK mains; el. panel and portable cable 50 m long on a coil to connect to AC mains; protective switch, el. heater for the interior and a metal safe for documents. PPTK TS is manufactured on the base of GAZ 2705 or Ford Transit. LTK-P 4x2, has been painted using special colour for traffic inspectors vehicles pursuant to GOST 50574-93 and is equipped with a signalling loud-speaker unit SGU.



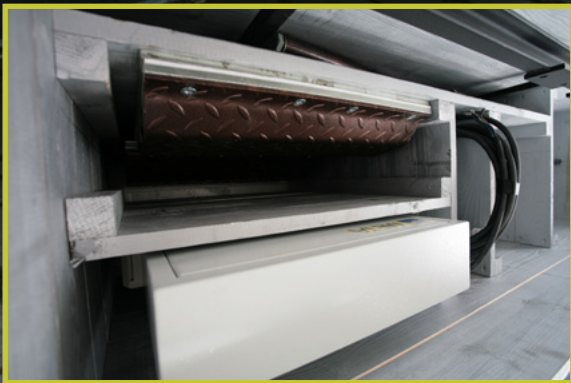

PPTK combined with STM-3000M.02 — is a comprehensive mobile diagnostic station with autonomous power supply.

At present META has set up mass production of a mobile low-profile stand STM-3000M.02, which may be transported in a trailer, and carry out vehicle brake system inspection in any conditions. The trailer is equipped with a diesel generator which makes the diagnostic station completely independent in terms of power supply

Advantages:

- Automatic data input enables a five-fold increase in line throughput.
- Full autonomy of diagnostic instruments and office equipment operation thanks to onboard mains.
- A comfortable office on wheels with two work-stations.
- High mobility.

Arrangement of PPTO control posts

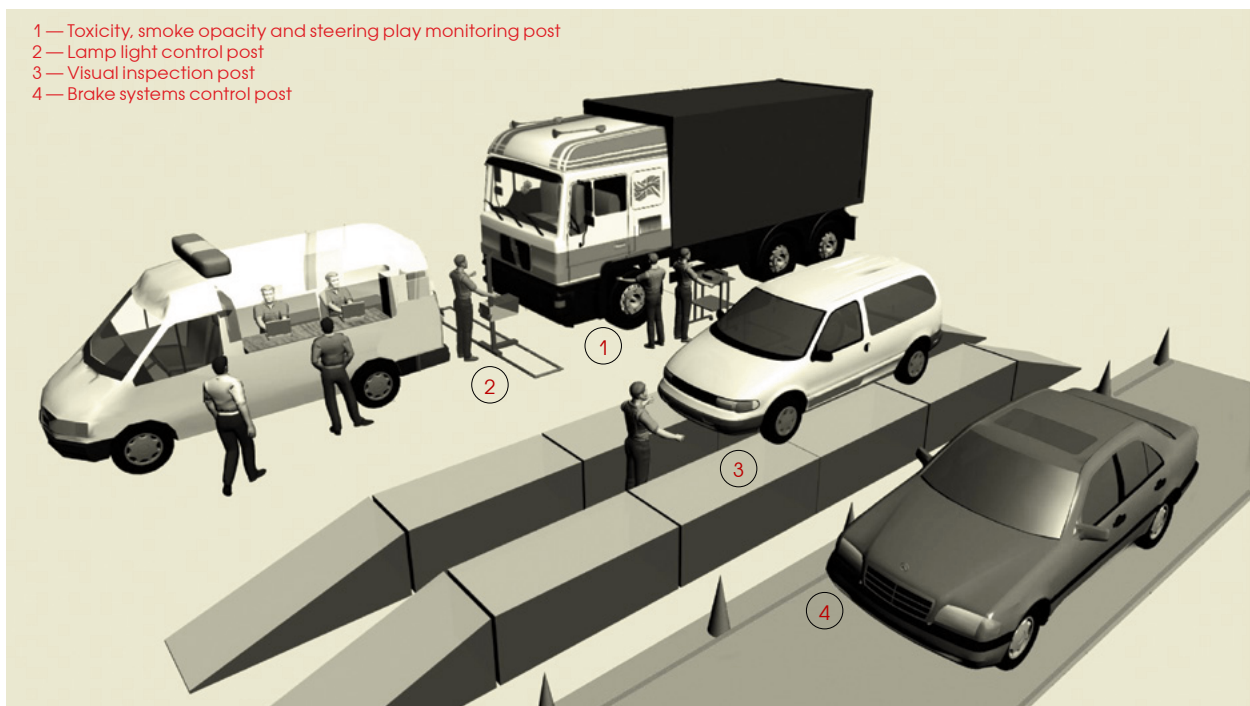

To carry out vehicle road test it is necessary to find road sections or sites with dimensions 6x120m.
 To set up three diagnostic posts an area 6x20 m is required

Video-registration systems during technical inspection of a vehicle

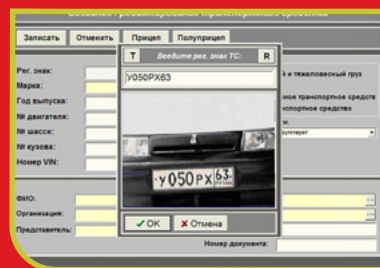

Vehicle video registration systems are designed to set up a database of photographic originals of vehicles submitted for technical inspection.

META manufactures two video-registration systems modifications:

MVK REGISTRATION SYSTEM

MVK vehicle video registration system creates a database of photographic originals of the vehicles, automatically recognises and identifies vehicles from the registration base of the traffic police. During vehicle registration the recognition video-camera switches on and with the aid of a special software module the system automatically reads the car number. It is then entered into the data base by an operator and linked to the relevant photographic image of its external appearance, indicating registration date and time. Based on the number recognised passport data of the vehicle is uploaded from the registration base to compare with information in the Vehicle passport.

Advantages:

- Automatic vehicle recognition and identification from the data in traffic police data base.
- Viewing and observation of events at technical inspections stations in real time at the inspector's working station.
- Automatic vehicle video-registration as electronic photographic original with date and time link.
- Comparison of vehicle parameters based on photographic original and registration documents.
- Outside audit of State technical inspection based on photographic archive of stored images.
- Technical inspection blocked if registration data do not match.

SVR VIDEO-REGISTRATION SYSTEM

Solution that ensures economies for technical inspection stations

Vehicle video-registration system SVR enables taking photographs and videos of the vehicle storing the vehicle image in memory.

Advantages:

- Viewing and observation of events on technical inspections stations in real time at the inspector's working station..
- Automatic vehicle video-registration as electronic photographic originals with date and time link.



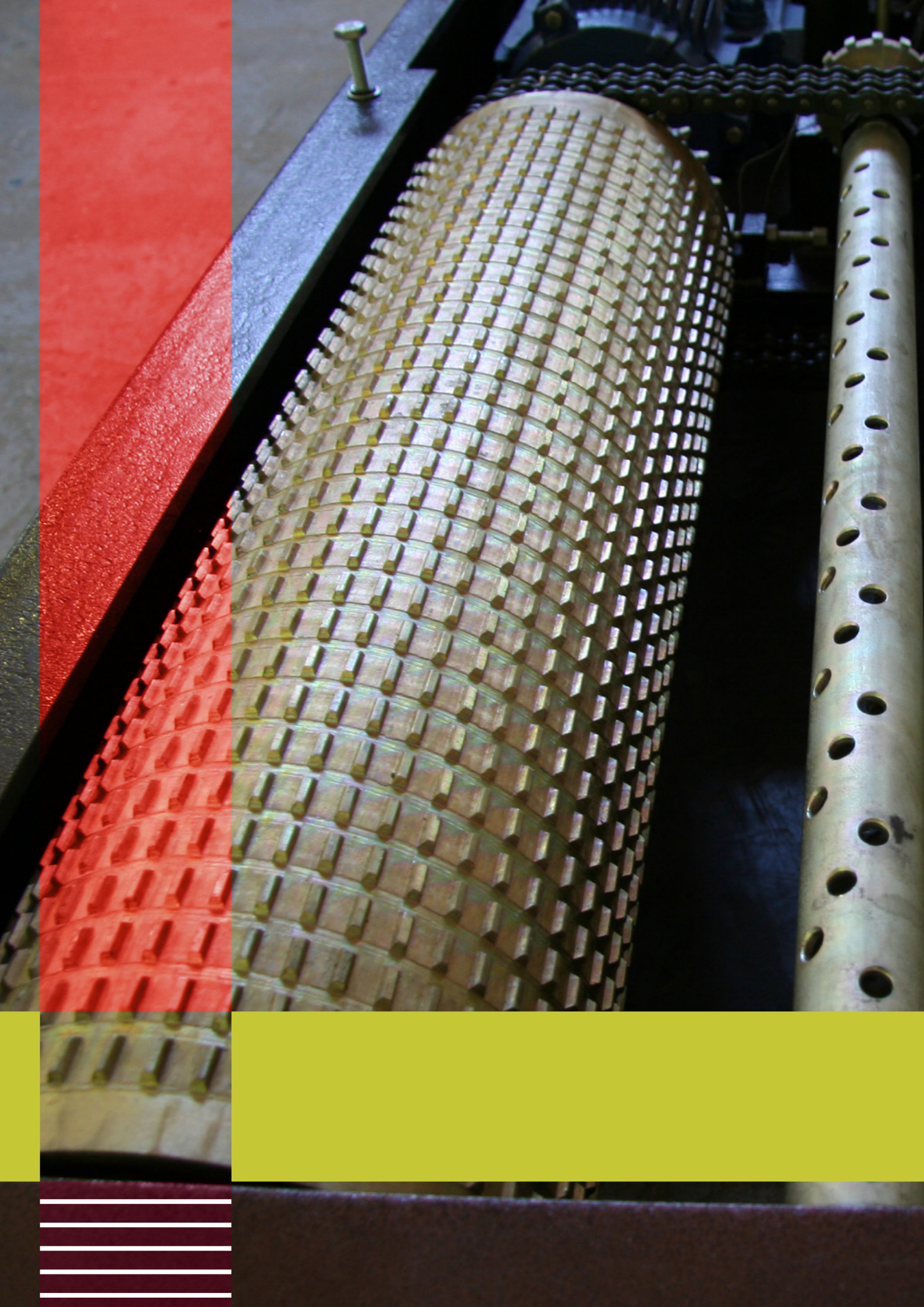

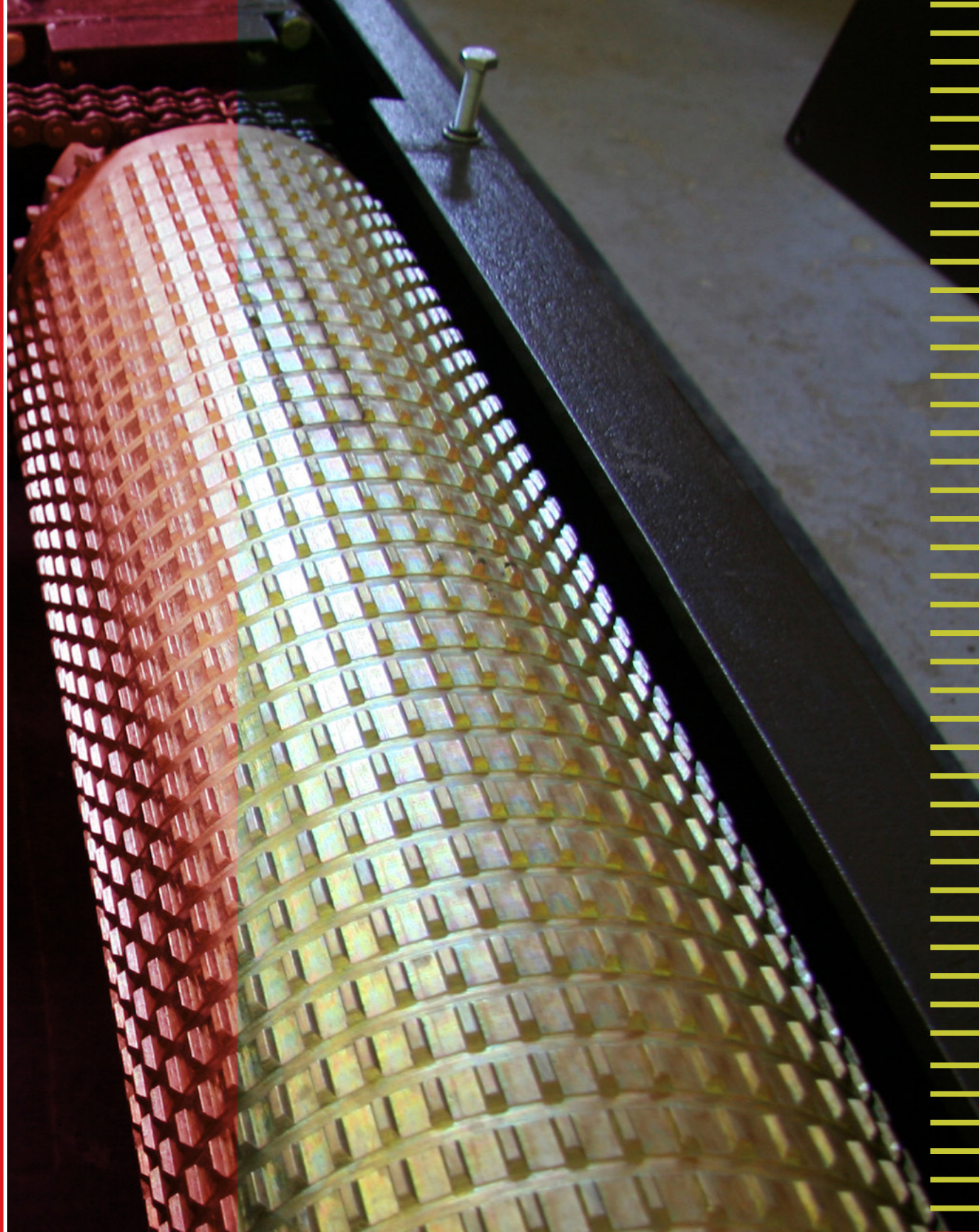

Diagnostic equipment

UNIVERSAL BRAKE STANDS STM



Universal brake stands STM manufactured by META provide the best solution in vehicle brake systems diagnosis. In 1999, for the first time in Russia the company developed and started mass production of low-profile brake stands STM 3500. During this period the company introduced over 20 models of brake stands with various load carrying capacities and force.

A large range of brake stand models includes new modifications intended for testing motorcycle and heavy duty lorries brake systems, as well as unique low-profile portable stands which do not require the floor to be recessed to place a technical inspection station on the floor. New models of brake stands are equipped with noiseless planetary engine reduction gear with a higher twisting rigidity and the ability transmit high torque.

Special strain-measuring sensors manufactured by us ensure high precision of weight and braking force measurements during passenger car and lorry tests with axle load of up to 18 t. in a wide range of work temp. from - 30 to +60 eC. Our block transportable brake stands which permit the operator to carry out a quick set up of technical control lines both on sites and in existing technical inspection stations have enjoyed great popularity.

To produce wear-resistant STM roller coating META uses surface cementation and hardening to 60-62 HRC, which ensure long-term stand operation without the loss of necessary engagement with vehicle. All the components of STM roller unit are protected from corrosion by a zinc coating painted with polymer paint. This gives high quality equipment with an advantageous price not comparable to the price of other manufacturers is achieved.

Special software enables the display of measurement results on computer monitor, gives commands on car driving during testing, stores data of vehicles tested, plots changes in braking force over time, and when operating in a technical control line transmits measurement results onto a diagnostic card.

Remote control of brake test stands via radio-console do not need 'targeting' on the receiver and enhance the convenience and safety during stand control from the cabin of the vehicle tested.

Additional components for the STM stand are: slip tester, shock absorber test stand and trailer loader which permits to set up a complete diagnostic line satisfying the requirements of leading automotive manufacturers.

Functions:

- Automatic measurement and brake systems parameter calculation in accordance with GOST R 51709-2001 requirements set out in the order of the Russian Trade and Industry Ministry dated.12. 2011 no. 1677 'On approval of chief technical characteristics of technical diagnostic equipment and their list' based on the following indicators: braking force achieved by vehicle braking systems; weight load applied to vehicle axle; effort applied to controls of vehicle braking systems.
- Display of measurement results and their graphic interpretation on monitor screens and information indicator board.
- Automatic control of measurement modes based on GOST programme and methodology or in radio-console manual mode.
- Print-out of measurements protocol and braking force graphs.
- Display on monitor screen and light signal of driver and operator instructions.
- Automatic stand operation in technical control line and production of vehicle diagnostic card.
- Component-by-component addition of instruments to the diagnostic stand within the technical control line.



Advantages:

- Vehicle self-alignment during tests, automatic on-off drives switching when driving onto and driving off the ramp.
- Enhanced wear-resistant rollers resulting from special type of hardening and surface treatment. Roller coating is totally resistant to tyres with anti-skid studs.
- Anti-corrosion protection of roller elements in STM unit: powder polymer paint.
- A wide range of working temp. from -10 °C to +40 °C makes it possible to use the stand in un heated premises or in container mobile diagnostic stations.
- Dynamic measurement of wheel braking force and axle loads when braking, taking into account axles' load when braking.



STM 1500

Brake test stand for monitoring braking systems effectiveness and stability of motorcycles with axle load of up to 1500 kg, track width up to 198 mm and wheel diameter (on tyre) from 500 to 850 mm.



STM 3000M.01

Single block, low-profile, small-sized brake stand STM 3000M.01 is intended for checking braking systems of passenger cars and lorries of all types with axle load of up to 3 t.



STM 3000M.02

Small-sized, low-profile brake stand for testing passenger cars with a full drive and of mini-buses with axle load of up to 3 t, track width up from 800 to 220 mm and wheel diameter from 500 to 850 mm. Ramp height 160 mm. Optimal arrangement version for technical control stations and travelling technical inspection points. Supplied as a mobile option with a trailer. Thanks to roller unit weighing 170 kg made of two parts it is easy to move the stand and this makes it possible to set up a travelling technical inspection point with a portable brake test stand which may be transported in the trailer. Recommended dimensions of industrial premises - 5 x18 m.



STM 3500

Brake test stand to check the brake system of passenger cars with a full drive and minibuses with axle load of up to 3,5 t. This low budget model has no computer rack or weight sensors. This is an economic solution for those who are starting out in business. Later on weight sensors may be added, which would ensure its compliance with GOST R requirements and Technical regulations. Recommended dimensions of industrial premises – 5x18 m.



STM 3500M

Brake test stand to check the brake system of passenger cars with a full drive and minibuses with axle weight of up to 3,5 t, track width 800 - 2210 mm, wheel diameter from 500 to 1020 mm.

TECHNICAL SPECIFICATIONS

Stand modifications	Braking force measurement range, k kN	Stand power consumption, kWt, No more than	Weight measurement range of axle, kg	Effort measurement range on controls, N
STM 3500	From 0 to 10	7	from 0 to 3500	From 0 to 1000
STM 3500 M	from 0 to 10	7	from 0 to 3500	
STM 3000 M.01	from 0 to 10	4	from 0 to 3000	
STM 3000 M.02	from 0 to 10	4	from 0 to 3000	
STM 1500	from 0 to 5	2,5	from 0 to 1500	
STM 6000	from 0 to 18 from 0 to 27	10,5* ¹ 9* ²	from 0 to 3500 from 0 to 6000	
STM 10000	from 0 to 25	12	from 0 to 10000	
STM 13000.01	from 0 to 30	13	from 0 to 13000	
STM 13000.02	from 0 to 30	12	from 0 to 13000	
STM 16000.01	from 0 to 40	13	from 0 to 16000	
STM 16000.02	from 0 to 40	16	from 0 to 16000	
STM 18000	from 0 to 24 from 0 to 60	19* ¹ 16* ²	from 0 to 9000 from 9000 to 18000	

Note: *¹ – stand power in 1st gear;
*² – stand power in 2nd gear



STM 6000

Universal dual-speed single block brake test stand to check brake systems of all types of passenger and cars and lorries with axle load of up to 6 t., track width 900-2760 mm and wheel diameter from 500 to 1020 mm.



STM 10000, STM 13000.01

Universal single block-type brake test stand to check brake systems of all types of passenger and cars and lorries with axle load of up to 10 and 13 t., track width 960-2800 mm and wheel diameter from 500 to 1020mm. Recommended dimensions of industrial premises – 7.5 x 18 m



STM 16000.01

New single block-type universal brake test stand to check brake systems of all types of passenger cars and lorries with axle load of up to 16 t., track width 960-2800 mm and wheel diameter from 600 to 1200mm.. Recommended dimensions of industrial premises – 7.5 x18 m



STM 13000.02 and STM 16000.02

Universal modular brake test stand to check brake systems of all vehicle types, including heavy-duty lorries with axle load of up to 13 and 16 t., track width 900-2900 mm and wheel diameter from 600 to 1200mm. Recommended dimensions of industrial premises – 7.5 x18 m



STM 18000

Universal two-speed modular brake test stand to check brake systems of all vehicle types, including heavy-duty lorries with axle load of up to 18 t., track width 900-2900 mm and wheel diameter from 600 to 1200mm. Recommended dimensions of industrial premises – 7.5 x18 m

TECHNICAL SPECIFICATIONS						
Stand modifications	Start time of operational mode , min.	Dimensions, mm, no more than		Weight, kg, no more		Working temp. range
		Roller unit	Control cabinet	Roller unit	Control cabinet	
STM 3500	15	2340x680x290	550x460x120	470	20	from minus 10 to plus 40°C
STM 3500 M		2320x680x320		550		
STM 3000 M.01		2320x610x220		360		
STM 3000 M.02		1400x750x230		170*2		
STM 1500		1400x750x230	170			
STM 6000		2960x680x335	650x500x141	800	27	
STM 10000		2950x730x340	550x460x120	860	20	
STM 13000.01		2950x730x340		1150		
STM 13000.02		1800x730x320		850*2		
STM 16000.01		2950x730x340		945		
STM 16000.02		2010x800x440		600*2		
STM 18000		2010x810x440		650x500x141		

LATERAL (SIDE-SLIP) SLIP TESTER

Lateral slip tester is intended for monitoring and data acquisition on linear movement of all vehicle axles. Measurements are performed during car travel along the test plate which at that time shifts right or left, depending on lateral wheel slip. Helps to prevent premature tyre wear.

META manufactures two modifications of this tester: TU-3000 for passenger cars and TU-15000 for lorries

Advantages:

- Graphic interpretation of measurement results by means of a cursor.
- Test results are displayed on the monitor in m/km.



TECHNICAL SPECIFICATIONS

DESIGNATION	Parameter value	
	TU-3000	TU-15000
Max. axle load, kg	3000	15000
Measurement range, M/km	±15	±20
Division value indicator, m/km	±0,1	±0,1
Error, no more than, m/km	±0,2	±0,2
Dimensions, no more than, mm,	800x460x50	1000x800x100
Weight, kg, no more than	55	192

SUSPENSION TESTER STAND

SPP 2500

This tester is intended to monitor the condition of vehicle suspension. Enables objective assessment of suspension's ability to accept a load and revert to initial position as well as find out vehicle's tendency to 'slip' when wheels are at correctly positioned.

Advantages:

- Measurement results shown as percentages.
- Report on results print-out in two formats: table and diagram.



SPECIFICATIONS

Oscillation amplitude	6 mm
Oscillation frequency	23 Hz
Axle load, no more than	2,5 t.
Engine HP	2x1,5 kWt
Track width	800-2300 mm
Dimensions	2500x550x350 mm

REMOTE CONTROL CONSOLE PDU (RCC) STM

Combined radio-console for vehicle visual inspection and remote control of brake test stand RCC STM is intended for electronic recording of vehicle parameters from visual assessment. Stand control and transmission of radio-commands and assessment protocol are done via radio-channel. Tested specification is selected on the console display and an assessment of compliance is performed, the results in protocol format with vehicle registration no. included are transmitted to LTK computer via radio-channel and entered into the relevant diagnostic card.

Functions:

- Remote control of brake test stand operation.
- Electronically recorded visual assessment of vehicle parameter results.



Advantages:

- Fiscal memory of measurement results.
- Diagnostic card automatically filled in.
- Messages appear when supply voltage drops below normal
- Automatic transmission of visual inspection results to the central computer via radio-channel.



TECHNICAL SPECIFICATIONS

Guaranteed coverage zone in open space no less than , m	8
Alpha-numeric display	2 x12
Dimensions, mm, no more than	170 x67 x22
Weight, kg, no more than, kg,	0,2
Power supply to console from built-in battery	3,6 V, 700 mA•h
Power supply to console receiver:	
AC mains	220 V
External power supply unit	50 Hz

DYNAMIC ROLLER TEST STANDS

SDM 2-3500.200, SDM 3-15000.150, SDM 4-15000.150

Dynamic roller stands are intended for a comprehensive assessment of vehicle's technical parameters by fully imitating its travel within a wide range of speeds. The base of the stand's mechanical part is a wear-resistant, maintenance-free structure which guarantees long-term operation. The rollers are zinc-coated which ensures full protection from corrosion. Using the dynamic stand it's possible to recreate road conditions without driving into the street which helps save time and money.

Dynamic stand offers error-free diagnostics for the development and updating assemblies and units of new models and is an irreplaceable tool for assessment of commercial vehicles coming off the manufacturer's conveyor.



Functions:

- Vehicle acceleration on test stand up to 150 km/h. and 200 km/h, and braking at any speed in the range.
- Monitoring the functioning of engine control unit (module) ECU).
- Assessment of vehicle transmission mechanical losses.
- Fuel consumption assessment with vehicle moving at steady speeds.
- Vehicle dynamics assessment with acceleration in the range 0 -100 km/h.
- Vehicle power parameters measurement based on acceleration dynamics.
- Visual assessment of engine cooling system ventilator operation, speedometer, lighting instruments, audible signals.
- Dynamic functional tests during driving, parameter and main vehicle units at different dynamic driving situations monitoring in typical road conditions.

Advantages:

- The basis of the mechanical part of the dynamic test stand is a wear-proof easy to maintain construction guaranteeing long-term uninterrupted operation.
- Using a power stand it is possible to recreate road conditions for the vehicle without driving outside into the street. Hence test results do not depend on weather, which saves time and money.
- Graphic test process may be done both using software and remote control console.

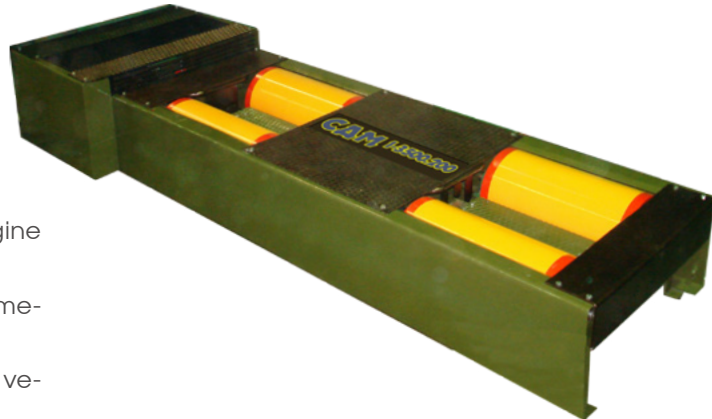

Controls of roller stand ensure:

- automatic reading along diagnostic line (K-Line) of ECU controller passport data;
- reading along diagnostic line (K-Line) error codes of the built-in onboard diagnostic system to analyse presence and working order of sensors, actuators and their conformity with vehicle type;
- documenting control results of ECU functioning with conclusions printed out in the form of a protocol;
- automatic self-diagnostics, equipment fault determination, operator's mistakes.



For Scientific-research institute 21 of the MoD «META» developed a 4-axle drum based stand SDM 3-15000.150.

It is intended for scientific trials and finishing operations of military vehicles. It is equipped with the most up-to-date measurement devices for fuel consumption, tractive effort, temp. at various points in units and assemblies (up to 100 channels) etc. In addition, various temp. regimes, mountain regimes and on-coming air flow speed can be modelled.

META mass produces a single-axle dynamic power roller stand SDM 1-3500.200., whose advantage is based on a new design solution – replacement of the el. drive by an induction brake, and this innovation, due to minor changes in functional abilities, significantly reduces cost.



TECHNICAL SPECIFICATIONS

	SDM 2-3500.200	SDM 3-15000.150
Stand weight, t. no more than	7	50
Vertical axle load, Kn	3	150
Number of driving axles	2	4
Dimensions, mm, no more than	5500x2800x1100	12000x4700x1000
Range of braking force measurement (tractive effort) on one wheel, N	0-3000	0 - 30000
Effort measurement range on control unit, N	from 0 to 1000	from 0 to 1000
Track, mm	600...2100	-
Max. rotation speed of driving roller, km/h	200	150
Range of wheel base regulation, mm	2200...2900	-
AC current 3-phase voltage, V		380±10%

MULTI-COMPONENT GAS ANALYSERS **AUTOTEST**

For 25 years META has occupied a leading position in the manufacture of diagnostic equipment and offers the widest range of multi-component gas analysers AUTOTEST to monitor the toxicity of vehicle exhaust gases.

Multi-component gas analysers are mass produced since 1994. The early models were manufactured on an analogue base. META was one of the first companies to undergo modernisation to start mass production of gas analysers AUTOTEST based on microprocessors. Thanks to the introduction of new technologies the precision of its instruments increased to satisfy the requirements of European standards EURO-3 and EURO-4. In 2006 microprocessor gas analyser cell base was replaced by chip-components and SMD-technology which significantly improved the quality of our instruments.

AUTOTEST gas analysers evolution started from 2-component CO-CH₂ class analysers and cursor indication and grew to 5-component CO-CH-CO₂-O₂-NO_x analysers of zero precision class based on modern microprocessors with colour displays. Its early models differed from similar devices of other manufacturers due to their high reliability, simplicity and a wide range of operating temperatures, and as a result enjoyed a good reputation in technical inspection centres, in environmental inspectorates and in toxicity adjustment points. Many users of the early models even today, after 15 years, still keep their 'faithful' instruments and regularly bring them for testing and preventive maintenance.

In its development plans relating to diagnostic instruments series for technical inspection purposes META created a special model AUTOTEST-LTK with result transmission via radio-channel into the station's central computer. Today over 20 000 gas analysers are in use, including for LTK - ab. 5.5 thousand. The new model 'AUTOTEST 2013' is equipped with a measurement channel for NO_x oxides based on permanent spectrophotometric sensor instead of an electrochemical one whose service life is limited.

Today gas analysers AUTOTEST are certified in all the CIS states, Bulgaria; its certification in the UK, other European countries, and in America is nearing completion. It was awarded medals and diplomas for its high and stable quality by Russian and foreign Quality programmes.



- Gas analysers AUTOTEST have demonstrated their reliability as low cost maintenance devices, which are successfully used in technical inspection stations, vehicle service outlets and motor depots.
- Gas analysers AUTOTEST are equipped with powerful and effective micro-processors which has enabled them to achieve high measurement precision of the 5 toxicity components: CO, CH, CO₂, O₂, NO_x.

In 1990-s, META developed a unique and economic solution for vehicle service outlets: CO-CH, gas analyser combined with smoke opacity meter AUTOTEST-01.04M, all in one unit which enabled not only toxicity but also smoke opacity of exhaust gases measurements.

Functions:

- Automatic condensate discharge.
- Three-stage sample cleaning.
- Measurement of 2 to 5 components: CO, CH, CO₂, O₂, NO_x.
- Calculation and indication of lambda parameter.
- An economic solution – an additional smoke opacity channel for diesel engines in CO-CH-D analysers.
- Print-out of measurement results protocol by built-in printer.
- Automatic zero correction without the need to switch off the sampling device
- Free software enabling graphic toxicity measurement results interpretation
- Interference-proof tachometer sensor.

Advantages:

- High precision and fast operation.
- Wireless remote control and indication console.
- Electronic calibration according to Gas Mixture testing.
- Heated sample delivery system.
- Input into protocol of state vehicle number.



Gas analysersb AUTOTEST series

Five component gas analysers with high-precision fast action colour display for scientific research and vehicle tuning of serial cars

0 precision class

AUTOTEST 02.03.P DU



AUTOTEST 02.03 DU



AUTOTEST 02.03P



II precision class



Two component gas analysers

AUTOTEST-01.02, AUTOTEST-01.02P with printer
AUTOTEST-01.02M without condensate discharge

Four component gas analyser

Autotest-01.04M

Two component gas analyser-smoke opacity meter

AUTOTECT-01.04M

Four component gas analysers

AUTOTEST-01.03 LTK for operation within LTK-META
AUTOTEST-01.03P with printer for operation within LTK-META
Autotest-01.04M

Two component gas analyser-smoke opacity meter

AUTOTEST-01.04, AUTOTEST-01.04P with printer

Four component gas analyser

AUTOTEST-01.03DU with remote control radio console

AUTOTEST 01.03 MINI

First gas analyser with autonomous storage battery in the world

Block construction AUTOTEST expands application range and enhances operational convenience:

- The optical block is located directly next to the exhaust pipe, and the control panel is held by the mechanic-controller.
- Time to determine readings – 6 secs.
- High reliability of measurement results.
- Radio-console operation radius – 10 m.

0 and I precision classes



Four component gas analysers

AUTOTEST-02.02, AUTOTEST-02.02P high precision, equipped with a printer, connection to remote control radio-console;

Five component gas analysers

AUTOTEST-02.03P high precision and fast operation, equipped with a printer, connection to remote control radio-console;



Three-phase sample cleaning system:

- Voluminous metal-woven filter
- Moisture-repellent fine filter.
- ultrafine gas cleaning GB702.



Heated sampling system (from 6 m) for operation with gas analyser in minus temp. up to -20°C



Interference-proof tachometer sensor



Stabilised power supply source from mains 220V, 50 HZ for gas analysers



Gas analyser sampling device probe with a protective casing made of non-corrosive mesh with built-in preliminary sample cleaning filter



Oil temp. sensor



Smoke opacity optical sensor

Gas analysers AUTOTEST I and II precision class in accordance with GOST P 52033-2003

TECHNICAL SPECIFICATIONS												
ФУНКЦИЯ	01.02	01.02P	01.02M	01.03	01.03P	01.03 LTK	01.03P LTK	01.03M	01.03DU	01.04	01.04P	01.04M
Класс точности	II	II	II	I,II	I,II	I,II	I,II	I,II	I,II	II	II	II
CO, % (±6%) measurement channel	0-7	0-7	0-7	0-7	0-7	0-7	0-7	0-7	0-7	0-7	0-7	0-7
CH, ppm (±6%) measurement channel	0-3000	0-3000	0-3000	0-3000	0-3000	0-3000	0-3000	0-3000	0-3000	0-3000	0-3000	0-3000
CO ₂ , % (±6%) measurement channel	no	no	no	0-16	0-16	0-16	0-16	0-16	0-16	no	no	no
O ₂ , (±6%) measurement channel	no	no	no	0-21	0-21	0-21	0-21	0-21	0-21	no	no	no
Lambda-parameter calculation.	no	no	no	0,5-2,0	0,5-2,0	0,5-2,0	0,5-2,0	0,5-2,0	0,5-2,0	no	no	no
Tachometer, m ⁻¹ (±2,5%)	0-8000	0-8000	0-8000	0-8000	0-8000	0-8000	0-8000	0-8000	0-8000	0-8000	0-8000	0-8000
Smoke opacity measurement channel, m ⁻¹ (±0,05 m ⁻¹ , absorption coeff. 1.6-1.8 m ⁻¹)	no	no	no	no	no	no	no	no	no	0-∞	0-∞	0-∞
Oil temp. measurement, °C (±2 °C)	20-125	20-125	no	20-125	20-125	20-125	20-125	20-125	20-125	20-125	20-125	no
«Autotest» software complete set, PC entry	yes	yes	yes	yes	yes	yes	yes	yes	yes	yes	yes	yes
Operation in LTK, software 'Diagnostic control'	no	no	no	yes	yes	yes	yes	no	yes	yes	yes	no
Remote control panel	no	no	no	no	no	no	no	no	no	no	No	no
Automatic condensate evacuation/additional compressor	yes	yes	no	yes	yes	yes	yes	yes	yes	yes	Yes	no
Automatic zero correction with gas sample cut-off	yes	Yes	no	yes	yes	yes	yes	yes	yes	yes	Yes	no
Pressure auto correction/ sample consumption control	no	No	no	no	no	yes	yes	no	yes	no	No	no
Autom. compressor disconnection on sampling system is blockage	no	No	no	no	no	no	no	no	no	no	No	no
Small-size thermal printer MTP-55	no	Yes	no	no	yes	no	yes	no	no	yes	No	no

* M — small size AUTOTEST

Gas analysers AUTOTEST I and 0 precision class according to GOST P 52033-2003

TECHNICAL SPECIFICATIONS									
FUNCTION	02.02	02.02P	02.03P	02.02	02.02P	02.03P	02.03P DU	02.03DU	
PRECISION CLASS	I	I	I	0	0	0	0	0	
CO, % (±4%) measurement channel	0-5	0-5	0-5	0-5 (±3%)	0-5 (±3%)	0-5 (±3%)	0-5 (±3%)	0-5 (±3%)	
CH, ppm (±5%) measurement channel	0-2000	0-2000	0-2000	0-2000	0-2000	0-2000	0-2000	0-2000	
CO ₂ , % (±4%) measurement channel	0-16	0-16	0-16	0-16	0-16	0-16	0-16	0-16	
O ₂ , (±4%) measurement channel	0-21	0-21	0-21	0-21 (±3%)	0-21 (±3%)	0-21 (±3%)	0-21 (±3%)	0-21 (±3%)	
Lambda parameter calculation	0,5-2,0	0,5-2,0	0,5-2,0	0,5-2,0	0,5-2,0	0,5-2,0	0,5-2,0	0,5-2,0	
Ability to connect NOx, ppm (±5%) measurement channel	no	no	0-5000	no	no	0-5000	0-5000	0-5000	
Tachometer, m ⁻¹ (±2,5%)	0-8000	0-8000	0-8000	0-8000	0-8000	0-8000	0-8000	0-8000	
Oil temp. measurement, °C (±2 °C)	20-125	20-125	20-125	20-125	20-125	20-125	20-125	20-125	
Complete set of Autotest software, input to PC	yes	yes	yes	Yes	yes	yes	yes	Yes	
Operation in LTK, software 'Diagnostic control'	yes	yes	yes	yes	yes	yes	yes	Yes	
Remote control panel	no	no	Special order	no	no	Special order	yes	yes	
Automatic condensate evacuation/ additional compressor	yes	yes	yes	yes	yes	yes	yes	yes	
Automatic zero correction with gas sample cut-off	yes	yes	yes	yes	yes	yes	yes	yes	
Pressure auto correction/ sample consumption control	yes	yes	yes	yes	yes	yes	yes	yes	
Autom. compressor disconnection on sampling system is blockage	yes	yes	yes	yes	yes	yes	yes	yes	
Small-size thermal printer MTP-55	no	yes	yes	no	yes	yes	yes	no	

BRAKE SYSTEM EFFECTIVENESS MEASURING DEVICE **EFFEKT-02**

EFFEKT-02 is used for checking braking systems in road tests for lorries, passenger cars, buses and trailer trains, as well as for electrical vehicles, trams, and trolleybuses during technical inspection. EFFEKT is absolutely indispensable for vehicle technical expertise during operation and vehicle placed on line for operational control of braking system condition.

Measurement interpretation software is supplied as a set together with EFFEKT-02 and it was updated in accordance with GOST requirements.

It is installed vertically in the car interior on the side window or on the floor with the aid of a clip. At present it is equipped with Li+ battery and pedal reinforcement sensor with a magnetic clamp.

Functions:

- Measuring braking characteristics and stability.
- Graphic display on a monitor of dynamic characteristics of braking in real time with the measuring device connected to a computer.
- Input of vehicle parameters and categories into instrument memory and measurements protocol print-out on a portable printer.
- Calculation of braking distance standard for any speed when braking is initiated.

Advantages:

- The whole technical control line can operate with automatic transmission of measurements results and vehicle characteristics.
- Convenient alpha-numeric display.
- Independent power supply from own storage battery.
- Electronic vertical position sensor.
- Alpha-numeric indication.
- Dual coordinate accelerometer.



Braking parameters are measured during road tests in accordance with GOSTP 51709 – 2001 requirements and the order of the Russian Ministry of Trade and Industry dated 6 December 2011 no. 1677 'On approval of main technical characteristics of technical diagnostic equipment and their list'.



Small size thermal printer MTP-55

TECHNICAL SPECIFICATIONS		
DESIGNATION	UNIT F MEASUREMENT	VALUE
Control range of steady deceleration	Jsteady m/sec ²	0-9,81
Control range of pedal Rp	N	98-980
Braking distance control range St	m	0-50
Control range of initial braking speed Vo	km/h	20-50
Control range of recalculated braking distance standard St	m	0-50
Control range of braking system operation t _{sr}	Sec.	0-3
Max. permissible main relative error of steady deceleration	%	±4
Max. permissible main relative error of pedal effort	%	±5
Power supply form DC mains (on-board vehicle)	V	12±2
Power consumption, no more than	Wt	2
Dimensions and weight of electronics unit, no more than	mm, kg	206x75x38; 0.4
Dimensions and weight of effort sensor, no more than	mm, kg	135x95x70; 0.5
Range of operating temperatures	°C	from -10 to +45
Average service life, no less than	years	6

EXHAUST GASES SMOKE OPACITY METER META-01 MP

Smoke meters META-01MP were developed and entered into mass production in accordance with the order placed by the Chief Directorate of Road Traffic Inspectorate of the Ministry of Internal Affairs of the USSR in Tashkent and are manufactured by META since 1989.

Early smoke meter prototypes were manufactured on an analogue base with an arrow indicator and were called compact smoke opacity meters KID-1 and KID-2 (1988 models). At present Meta has introduced new models based on microprocessors which enable the introduction of new functionalities into the smoke meter in accordance with international standard requirements of EEC UN and the environmental GOST R 52160-2003.

Patented original construction of the optical sensor, independent power supply, small dimensions and low weight ensured META-01MP smoke meter justly deserved popularity.

As early as 1991 it was awarded a gold medal at the International exhibition EXPO – 91.

During the period of its mass production a wide range of smoke meter models for all diesel types – from diesel locomotives to tractors and from marine to stationary power units based on standards and methods which enable smoke opacity measurements for Gostekhnadzor and Railways Ministry were manufactured.

Measurement of results and their processing using special algorithms based on well-tested methods, real time and expanded memory for 40 measurement results, optical measurement protection from air flow pollution – this is just some of the new technical solutions which have improved commercial properties and expanded smoke meter META-01MP application sphere.

At present META manufactures portable smoke meters with a photometric base of 0.1 and 0.2 m, and automatic recalculation to standards of the 0.43 m base as well as high-precision stand smoke meters META-01MP 0.43 with physical photometric base of 0.43 m.



Portable smoke meters

for cars

META-01MP 0.1
META-01MP 0.2



Small size thermal printer **MTP-55**

Additionally the customer may order a portable small-size printer with power supply from onboard vehicle mains for measurement results protocol printing.



- Automatic calculation of level of smoke is measured in accordance with the AUSS 52160-2003, AUSS 17.2.2.02, AUSS 50953-96 procedures for all types of vehicles.
- The photometric 0.1 and 0.2 bases are brought to the 0.43 base.
- Automatic zero and pollution control of optical elements.
- Telescopic handle attached to the optical sensor.
- Temperature control in the optical channel.
- Memory of the results and reporting with the protocol containing the results of measurements in different modes of testing of diesel, date, time, and vehicle license plate.

Stationary smoke meters

for cars, locomotives, as well as marine and river vessels.

META-01MP 0.43
META-01MP 0.43T



- Technical control is carried out via RS 232 by transferring of measurement results to a central computer.
- High precision and reproducibility of the results.
- A portable optical unit with a self-contained battery.
- A multi-function remote control.
- Classic photometric base of 0.43 meters.
- Operational management modes from the remote control to display the results on the alphanumeric display with backlight.
- A real-time clock to display the records of time and date.

TECHNICAL SPECIFICATIONS

	META-01MP 0.1 META-01MP 0.2	META-01MP 0.43
Range of smoke measurements in units of reduction factor, % in units of absorption factor, m ⁻¹	0-100 0-∞	0-100 0-∞
Limit of allowable absolute error with an absorption factor of 1.6-1.8, m ⁻¹ , no more	±0,05	±0,05
Photometric base of instrument, m leading to	0,43	0,43
Range of operating temperatures, °C	-20 +50	-20 +50
Overall dimensions, mm: instrument unit optic sensor control station	220x75x40 35x35x1500 -	640x190x310 - 220x75x40
Mass, kg instrument unit optic sensor sampling device control station smoke control module	0,4 0,6 - - -	- - 1,0 0,4 10
Electric supply: self-contained power supply (accumulator), B	11,1	12
Display		alphanumeric with lighting

METERS OF PARAMETERS OF HEADLIGHTS OF VEHICLES OF THE IAP-01 MODEL

Meters of parameters headlights of the IAP-01 model have been commercially available since 2002 and are an indispensable tool for monitoring, diagnosis and control of parameters of lighting devices of all types of vehicles in accordance with AUSS R 51709-2001 "Technical regulations on safety of wheeled vehicles." In 2012, new requirements on construction changes were amended and approved by a new certificate of conformity by the order of the Ministry of Industry and Trade of the Russian Federation of December 6, 2011, order No 1677 «On approval of the basic technical characteristics of the equipment and technical diagnostics and a list thereof».

The new design of the instrument, the use of a membrane keyboard, an updated element base, an extended measurement range and a built-in battery have improved the consumer properties of the updated device. For metrological support of IAP-01 a standard ETO-2 illuminator was developed and is now commercially available.

IAP-01 is a modern, effective means of assessing the parameters of light coming from headlights of vehicles which are in service, under manufacturing and after repairs and is used in various car-related enterprises, automobile factories, as well as during technical inspections of vehicles.

IAP-01 is certified for use in the CIS countries and Bulgaria.



Functions:

- Measures the angles of the light beam coming from headlights of cars.
- Measures the intensity of external light devices.
- Measures the time from the turning off of turn signals until the actual light appears.
- Measures the frequency of flashes of turn signals.

Advantages:

- A wide range of measured characteristics of lighting devices.
- The ability to record a vehicle's registration plate, measurement results are consistently accumulated for subsequent transfer to a computer.
- Self-powered.
- The device can be used at road sites with smooth asphalt or where cement concrete pavement is present, as well as in stationary conditions in car fleets and private cars by owners of the latter.
- Subsequent transfer of measurement results to a central computer.
- Works as part of LTC-META.



TECHNICAL SPECIFICATIONS	
NAME OF SPECIFICATIONS	VALUE OF SPECIFICATIONS
Range of slope angle measurements of light/dark boundary of a lamp light beam in a vertical plane	from 0°00' to 2°20'
Limits of allowable absolute error of slope angle measurements of light/dark boundary of a lamp light beam in a vertical plane	±0.1%
Limit of allowable absolute error of the optic camera unit of the measuring instrument in a horizontal plane	±30'
Range of measurements of the strength of light from external light sources	from 200 to 125000 kd
Limits of allowable fractional error of measurements of the strength of light from external light sources	±15%
Dimensions of the entry port of the measuring unit objective lens	233x170 mm
Range of repetition frequency of flashes of turn signal lights	from 1 to 2 hz
Limits of allowable absolute error of repetition frequency ranges of flashes of turn signal lights	±0.1 hz
Height of the measuring unit lift	from 250 to 1600 mm
Range of operating temperatures	from -10 to +40 °C
Power supply from dc source from built-in accumulator battery	from 10 to 14 V from 3.5 to 4 V
Mass, no more	20 kg
Average term of service, no less	6 years

ISL-M CONVERTERS FOR MEASURING ANGLES OF ROTATION

The versatile ISL-M device is designed to measure the total degree of loose steering of vehicles and tractors on top of rotation of the wheels in accordance with AUSS R 51709-2001 "Technical Regulations on Safety of Wheeled Vehicles In 2012, new requirements on construction changes were amended and approved by a new certificate of conformity by the order of the Ministry of Industry and Trade of the Russian Federation of December 6, 2011, order No 1677 "On approval of the basic technical characteristics of the equipment and technical diagnostics and a list thereof".

Mass production of the ISL-M measuring device began in 2002. The first model was an instrument unit with an optically mechanical rotation angle of the registrar, mounted on a telescopic capture and a heavy wheel-driven motion sensor. In the process of implementing of new innovational decisions, the design of registrar angle of the steering wheel was reversed and a gyro angle sensor was introduced. Replacing the optical-mechanical sensor of the steering wheel and the use of a new non-contact inductive sensor for a motion-controlled wheel led to a 100% increase of measurement accuracy, and the size and weight of the device decreased significantly as a result.

The ability to work gyro angle meter in any geometrical plane can eliminate the need for a spring-loaded rod attached to the glass, which greatly simplified the design of the capture mechanism. The built-in motion sensor NiCd-battery has been replaced by a LiION-battery.

The gyro angle sensor, the proximity sensor, the motion-driven wheels and a powerful microprocessor provide a combination of high precision, reliability and the ability to operate the instrument at a wide range of operating temperatures.



There has been added the capability to connect the device to external wireless TCL adapters. There is also new model which comes with a built-in radio module of its own design allowing you to work with a wireless line of technical control without the use of external adapters.

The 2013 model has an extended range of measurement in accordance with the Decree of the Ministry of Industry and Trade of the Russian Federation of December 6, 2011 No 1677 "On approval of the main technical characteristics of equipment and technical diagnostics and the list thereof."

Functions:

- Measures and displays the results of a single measurement of the total angle of loose steering.
- Automatically calculates the average backlash of individual measurements.
- Saves the results of the last measurement.
- Inputs the license plate number of the vehicle.
- Work as part of the TCL automated technical control

Advantages:

- High accuracy and reliability of the device as a result of the application of the non-contact motion sensor steering wheels and an electronic gyro angle sensor.
- Saves results when power is turned off.
- A powerful microprocessor.
- Self powered by use of the internal battery.
- Has the ability to save the results of the last measurement.
- Conducts automatic transmission of measurement results to a central computer.

TECHNICAL SPECIFICATIONS			
TITLE	VALUE		
	ISL-M	ISL-M.01	
Range of measurements of steering wheel position, degrees			0÷50
Limits of allowable absolute error of total play measurements, no more, degrees			± 0,5
Speed of steering wheel's return with measurement, no more, rev/s			0,1
Number of single measurements in the average of measured value, cycles			2÷9*
Time of one measurement of total play, no more, s			4
Allowable dimensions of steering wheel, mm			360÷550
Power supply from dc source, V	12,6 ^{+2/-4}		4,2 ^{-1,2}
Power intake in normal conditions, no more, W			5
Conditions of instrument operation: temperature of surroundings, oC			от -10 до +40
Overall dimensions, no more, mm			
instrumental unit	460×110×110		460×110×140
wheel motion sensor	310×200×135		-
Mass, no more, kg			
instrumental unit	3		3
wheel motion sensor	3		-
Mean time between failure, no less, hr			6000
Average term of service, no less, years			8

BACKLASH DETECTORS OF THE LD-4000, LD-4000P, LD-4000R, LD-8000 LD- 16000, LD-16000P, LD 16000R MODELS

Backlash detectors are designed to control backlash/ back-play in the joints of the steering and suspension vehicles with an axle load of 4 tons, 8 tons and 16 tons. The platforms of the back lash/back-play detector simulate all possible loads and are transmitted to the steering and suspension mechanisms of the car as it moves. The low platform height clearance detector allows you to even check cars with very low ground clearance.



Hydraulic back lash/back-play detector LD-4000

This device was designed for visual and sensory evaluation of gaps in the steering and suspension vehicles with an axle load of up to 4000 kg. It is used by transport companies, technical control centers and service stations, as well as during technical inspection of vehicles.

TECHNICAL SPECIFICATIONS	
Maximum load on platform, kg	2000
Run of platform, mm, no more	50
Movement power mechanism of movable platforms	Hydraulic
Motion control	Manual, remote
Power supply, V total control station	~380 (+10%/-15%) three-phase 12±2
Dimensional specifications of platform, mm, no more	600x500x66
Mass, kg	60
Conditions of product operation: temperature of surroundings, °C	from -10 to +40

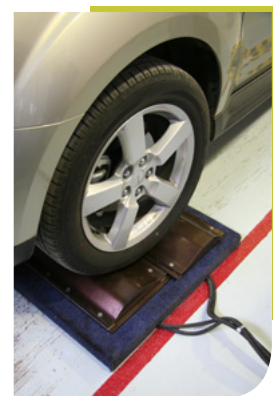

LD-4000

Pneumatic back lash/ back- play detector LD-4000P, 16000P

This device was designed to check the shock absorber and supports, ball joint suspension of the engine, the support arm, the rod end bearing set, etc. They are used by transport companies, technical control centers and service stations.

TECHNICAL SPECIFICATIONS		
Maximum load on platform, kg	2000	8000
Maximum axle load, kg	4000	16000
Run of platform, mm left/right front/back diagonal	55 60 80	76 82 111
Movement power mechanism of movable platforms	Pneumatic	Pneumatic
Motion control	Remote	Remote
Power intake, kW	2,2	2,2
Power supply, V	220 -10%	220 -10%
Dimensions of movable platforms, mm, no more	805x630x25	925x700x34
Dimensional specifications of platform, mm, no more	860x930x200	1060x1114x311
Mass of one platform, kg	86	185



LD-16000P





LD-16000

Hydraulic backlash/back play detectors LD-8000 and LD-16000

This device was designed for visual and sensory evaluation of gaps in the steering and suspension vehicles with an axle load of up to 8,000 and 16,000 kg. They are used by transport companies, technical control centers and service stations, as part of the general complex technical control of the vehicle, as well as for vehicle inspection. Backlash/back-play detectors are designed to operate on premises and can be installed on the car-lift, as well as in auto repair pits.

TECHNICAL SPECIFICATIONS		
	LD-8000	LD-16000
Maximum load on platform, kg	4000	8000
Run of platform, mm, no more	80	80
Motion control of movable platforms	Manual, remote	Manual, remote
Power intake, kW, no less	2,2	2,2
Hydraulic oil pressure, MPa (max)	16	16
Power supply, V		
- total	~380 three-phase	~380+10%-15% three-phase
- control station	12/24	12±2
Dimensions of movable platforms (length, width, thickness), mm, no more		
-large	900x750x20	900x750x26
-small	430x750x56	430x750x59
Dimensional specifications of buried portion of the product platform, (length, width, height) mm, no more	900x750x130	900x750x130
Mass of movable platform, kg, no more	190	214
Mass of stationary platform, kg, no more	217	231
Conditions of operation: surrounding air temperature, °C	from -10 to +40	from -10 to +40

Hand-held backlash/back play detectors LD-4000R and LD-16000R

This play detector is designed to test shock absorbers and supports, ball joint suspension, engine mount support, arm suspension, steering rods, wheel bearings, etc. of passenger cars. The product is used by transport companies, technical control centers and service stations.

TECHNICAL SPECIFICATIONS		
	LD 4000R	LD 16000R
Maximum load on platform, kg	2000	8000
Rod force	600-650 kgf	1900 kgf
Lever force	20 kgf	35-40 kgf
Length of lever	1.7 m	1.7 m
Run of platform center: - diagonal, mm, no less	80	80
Movement power mechanism of movable platform	manual	manual
Dimensions of movable platform (length, width, height), mm, no more	805x630x25	925x700x34
Dimensional specifications of platform, (length, width, height) mm, no more	860x930x200	1060x1114x311
Mass of platform, kg	75	160
Surrounding air temperature	from minus 10 to plus 40 °C	from minus 10 to plus 40 °C

LIGHT TRANSMISSION MEASURING DEVICE TONIC

The light transmission measuring device TONIC was designed for use on tinted and shaded glass and has been commercially available since 2005. It is an indispensable tool for technical inspection of cars. The device can be used by various technical services, traffic police and the Ministry of Transport as a means of enforcing technical control requirements on road safety. It can be used for inspection by diagnostic centers, control centers for safety of road transport, companies performing the work of tinting of car windows, as well during technical inspections of vehicles.



Functions:

- Measures light transmission of both neutral and colored glass.
- 10 hours of continuous operation with an indicator of battery charge.
- Memory results of the last three measurements of toning.
- Can do input of the License plate number of the car into the instrument measurement protocol.
- Can transfer measurement results to the computer of the TCL.

Advantages:

- Self-powered by its own battery.
- Accuracy of measurement is independent of the thickness of the glass.
- Auto-tuning of the standard baseline of measurement and ability to sound alarm if the thresholds of light transmission are non-standard.
- Fully automated measurement and documentation of results.



TECHNICAL SPECIFICATIONS

Range of measurement of light transmission	4 – 100
Increment of readings, %	0,1
Limits of allowable absolute error, %	± 2,0
Thickness of test glass, mm	up to 20
Preparation time for measurement, sec, no more	20
Power supply, V (accumulator battery Li-ion)	3,6
Current consumption, A, no more	0,16
Time of continuous operation without recharging, h, no less	10
Dimensional specifications, mm, no more	
measuring unit	180x90x45
battery charger	80x70x30
light	95x35
Mass, kg, no more	
measuring unit and light	0,5
battery charger	0,05
Conditions of operation: surrounding air temperature	from -10 to +40 °C

LEAK DETECTOR TC-META

Portable TC-MATE leak detectors have gained well-deserved popularity in the market of diagnostic equipment. Being small-sized, self-powered, easy to use and accurate has accounted for stable consumer demand.

Leak Detector TC-Meta is a portable device indicator for detecting leakage of flammable gases and vapors which may be present in gas appliances and fittings for industrial and domestic use in residential and industrial buildings. It detects such substances as methane, propane, butane, acetylene, ammonia, gasoline, alcohol, and many others.

Over the past few years, the device has been modernized with the extension of its indication range and the introduction of a digital display.



Functions:

- Detection of gas leaks during routine checks of the technical conditions of vehicles, as well as gas leakage in pipelines and at other times when you need to quickly detect the presence and location of a gas leak.
- Shows results on a digital display with backlight.

Advantages:

- The device comes with an extension cord, providing convenience for checking in hard-to-reach areas where possible leakage of combustible gas may be present.
- Self-powered from an internal battery.
- Can be used with headphones to facilitate operation in noisy areas.
- Has a switchable highly audible alarm.
- The housing is made of impact-resistant polystyrene.





TECHNICAL SPECIFICATIONS		
TITLE	UNIT OF MEASUREMENT	VALUE
Range of controlled concentrations (propane), no less LFL* portion	%	from 0 to 60 from 0 to 1.02
Device's warm-up time, no more	s	50
Operating time	s	10
Power supply from independent accumulator	V	1,4 A*ч
Current consumption, no more	mA	250
Charge control of accumulator battery	V	with a decrease to 3 V
Dimensional specifications, no more	mm	210x75x45
Mass, no more	kg	0,80

* LFL - Lower Flammability Level per GOST P 51330 19-99

HARDWARE AND SOFTWARE TCL SYSTEM

The hardware and software TCL system was designed for automatic transmission of results of the evaluation of technical condition of cars to the central computer in the form of measurement protocols. These results are identified by serial numbers that are entered on the panel of each unit.



Advantages:

- Allows for data collection, transmission and storage of measurement data via wired and wireless communication channels.
- Allows for multiple combinations of circuit diagnostics, increasing the capacity of the line five times.
- Communication with the computer via radio channel allows you to disconnect devices from the PC and transmit data from a distance of up to 300 meters.

BRAKE ACTUATOR TEST KIT

The M 100 test kit for checking pneumatic brake actuator system by META is the most efficient and reliable means for diagnosis of pneumatic and pneumatic-hydraulic brake systems of all types. Special pressure gauges provide for high accuracy measurement of air pressure in the indicating points, and on the control terminals of pneumatic brake actuators and help control of air leakage.



M-100

Functions:

- Measures air pressure in the indicating point of brake actuators.
- Measures air pressure in the control outputs of the drive.
- Incrementally verifies the technical condition of the pneumatic actuator.

The set consists of five MPZ-UU2 gauges (measuring range of 0-10 kg/cm², accuracy class 1.5, AUSS 2405-88). The gauges are labeled 1, 2, 3, 4, and 5 and have interconnecting hoses.



M-100-02

HEADLIGHT TESTER TF-01

Headlight tester TF-01 is designed to aid in setting up and testing of car headlights when controlling the technical condition of the external lighting of vehicles.

Advantages:

- A wide range of measured characteristics of lighting devices.
- Self-powered.
- The device can be used on the road at sites when there is even asphalt or cement pavement, as well as under stationary conditions when working with car fleets and inside of garages.



The headlight tester can measure the following parameters:

- The angle of the light beam of headlights of cars;
- The intensity of external light devices;
- The time lapse between when the turn signal is turned on until the appearance of the light;
- The frequency of the flashes of the turn signal.



TECHNICAL SPECIFICATIONS

Type of device	stationary, portable
Method of determining slope angle of light beam	according to position of light/dark boundary on the device's screen relative to layout
Height of the measuring unit lift, mm	250-1200
Range of readings for the slope angles of light beam in a vertical plane, angle minutes	0 - 140
Dispersion of readings for the slope angle of light beam in a vertical plane, angle minutes	± 15
Range of readings of the strength of light from external light sources, kd	0-20000
Dispersion of readings of the strength of light from external light sources, %	±15
Amount of compensation from a flash of external light sources, kd, no less	10
Power supply - from accumulator battery	3.7 V 1600 ma *hour
Dimensional specifications of device, mm, no more	1380 x 650 x 524
Mass of device, kg, no more	18

TESTER OF LABELING DATA COMPONENTS AND ASSEMBLIES, DETECTOR NM

The indicator of Detector HM is designed to rapidly detect irregularities of the structure of the metal in its surface layer caused by different kinds of defects.



The device can be used in a laboratory and by the units of traffic police to detect signs of unauthorized changes to labeling of motor vehicles, according to the following factors:

- The weld;
- Inclusions of non-ferrous metals;
- Plastic deformation;
- Changes in the thickness of paint.

Functions:

- Identifies the structural failure of the metal in its surface layer.
- Detects changes the thickness of the paint.



Advantages:

- Wide operating temperature range from -10 to +40 °C.
- Easy to handle because it is self-powered.
- Time of continuous operation with a charged battery is at least 8 hours.

TECHNICAL SPECIFICATIONS

Display type	visual (graphic, acoustic, digital)
Unmonitored area from the product's edge, mm, no more	10
Thickness of monitored product, mm, no less	0,7
Device's power supply accumulator battery 8.4 V with output of no less than	170 mAh
Time of device's continuous operation with a power supply from a fully charged accumulator battery, h, no less	8 (with disconnection of display light and acoustic display)
Dimensional specifications, mm, no more	175x85x30
Mass, g, no more	270

INDICATOR OF FLUID CONTAMINATION

WHI-M

Indicator of fluid contamination WHI-M is designed for rapid control of impurities in fuel and oils (gasoline, diesel fuel, engine, hydraulic, and transmission oils) of vehicles, as well as in the process of testing engines and filters.



Functions:

- Allows you to control contamination in the range of 0.00 to 2.00%.
- Allows you to get information on the percentage of impurities in accordance with AUSS 17216 standard values.

Advantages:

- The indicator is easy to use, requires no special laboratory conditions, additional equipment nor highly skilled personnel.
- A built-in temperature sensor.
- A convenient digital display.



TECHNICAL SPECIFICATIONS

TITLE	UNIT OF MEAS.	VALUE
Temperature of controlled liquid	°C	20-65
Range of contaminants display	%	0.00-2.00
Display of measurement results:	digital	
Warm-up time of contaminant display, no more	s	10
Power supply from built-in accumulator Li-Ion	-	3.6 V 2 A *hour
Dimensional specifications and mass of electronics module, no more	mm, kg	200x75x40, 0.3
Dimensional specifications and mass of feeler-sensor, no more	mm, kg	W = 8.5 L = 560; 0.1





Weight-measuring Equipment

MOBILE WEIGHT CONTROL UNIT

MWC

The mobile weight control unit is designed to control the weights within parameters accepted for transport of heavy loads on public roads, and to facilitate the collection of fees and compensation for damage caused to roads, as well as impose penalties for violations of the existing restrictions on axial loads on roadways.



The unit is equipped with portable scales car of the VA-15S-2 or VA-15S-2M model or VA-20D-2 weights for weighing vehicles in motion. These are designed on the basis of the Russian GAZ 2705 vehicle or Ford Transit with colorful interior design. The units are equipped with:

- A desktop with two places for a safe to store valuable documents, with drawers and outlets for a computer and fluorescent light.
- Two swivel chairs.
- A storage box to accommodate the weighing platforms.
- A locker to place and secure the equipment during transportation.
- An interior heater, a fire extinguisher and a first aid kit.
- An extension cable to connect the equipment to external power supply at 220V.
- An extra high-capacity battery (12V).
- A battery charger to ensure uninterruptible power supply (12/220V).
- VA-15S-2, V-15S-2M or VA-20D-2 scales with a remote control.
- A "Weight Control" software package

Advantages:

- A mobile and self-sufficient unit
- A wide range of operating temperatures.
- Easy to install, does not require major construction work.
- Easy maintenance and metrology.
- Remote transmission of the results of measurements to the control panel.
- Able to print out a measurement protocol.



TRUCK SCALES (PORTABLE)

META weigh measuring equipment can measure axle loads of any PBX with a maximum of 24 tons.

SPC META has 20 years of manufacturing of high precision load measuring equipment which has been used successfully by Federal traffic police departments in different regions of Russia and near abroad.

During this time, the company put into operation more than 2,000 sets of weights on the fixed and mobile posts of weight control on the territory of Russia and other CIS countries.

The scales are being used in the service of the Federal Highway and Traffic Police departments in overseeing compliance with weight regulations on public roads.

In honor of the 25th anniversary of the company, the developers working for META achieved a record of accuracy of VA-15S scales to ± 5 kg and in measuring loads of up to 24,000 kg. The first model of the VA-15S-1 scales which was released last century had the accuracy of ± 50 kg, so the precision of the scales has increased tenfold!

Currently SPC META produces a wide range of portable VA-15S, truck scales which will fulfill the needs of virtually any relevant enterprise.

During the production of VA-15S, modernization of the scales was carried out through the use of high-strength materials, thus reducing the height of the platform to expand the range of objects weighed. The transfer of data from the weighing platform is carried out over a radio channel.

Functions:

- Automatic registration of axle loads of vehicles in a static mode.
- Printing out the protocol weight control on a built-in thermal printer control panel: the date, time and the axle load.
- The data transmission is in digital form and is transmitted from the platform to the terminal.
- Maintenance of a database of measured information by using dedicated "Weight control" software.
- Creation of a database containing information about the axle load and, the information about possible exceeding of the allowed limits of the axle load of the vehicle passing through the weighing platform.
- Creation of shift reports.
- Automatic calculation of the amount of fine for the carriage of excessively heavy cargoes according to the standards decided by the Government of the Russian Federation as of November 16, 2009 Order number 934 "On compensation for damage caused by vehicles engaged in transportation of excessively heavy goods by roads of Russian Federation.
- Print of single collection receipts without interrupting of the monitoring.

VA-15S-2
VA-15S-2MVA-15S-3
VA-15S-3M

Advantages:

- A wide range of operating temperatures.
- Easy installation and maintenance.
- The ability to transfer data on passing or failing weight standards from the terminal platform over a wireless communication channel.
- Dedicated "Weight Control" software which allows creation of a database of measurements, automatic calculation of the amount of fines, and reporting on the work of the post of weight control. This software also prints a control protocol on the built-in thermal printer of the control panel.
- The device is built by using only chemically resistant materials: stainless steel, seals, gaskets, load cells and strain gauges which are produced internally, which eliminates the dependence on external manufacturers.

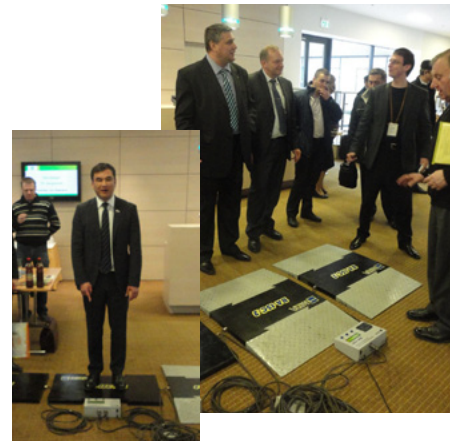

"These are really good scales!" Said Mr. Sergey Ten, the State Duma deputy, and the Deputy Chairman of the Committee on Transport, when testing the VA-15S-2 scales at the conference of the Association of Russian Regional Administrations of Roads (RADOR)

TECHNICAL SPECIFICATIONS

	VA-15S-2,	VA-15S-2M	VA-15S-3	VA-15S-3M
Maximum load (Max), kg	24000		24000	
Minimum load (Min), kg	400		200	
Testing interval, (e) actual value of dial interval, (d), e=d, kg	20		10	
Number of testing intervals	1200		2400	
Limits of allowable absolute error for initial calibration, ±kg				
in a range from Min to 500e inc.	10		5	
in a range higher than 500e to 2000e inc.	20		10	
in a range higher than 2000e	30		15	
Limits of allowable absolute error for operation, ±kg				
in a range from Min to 500e inc.	20		10	
in a range higher than 500e to 2000e inc.	40		20	
in a range higher than 2000e	60		30	
Range of empty weight sample, kg, no more	500		500	
Range of operating temperatures, °C				
for load carrier			from minus 40 to plus 50	
for terminal			from minus 10 to plus 50	
Parameters of power supply:				
current, V			220 ^{+12,5%} / _{-1,15%}	
DC source power supply unit, V			12 ^{+4%} / _{-2%}	
Dimensional specifications, mm, no more*2	700x400x40	900x500x40	700x400x105	900x500x105
Mass, kg, no more*2	36	42,5	42	67,5

Note*2- Characteristics given for one load carrier

TRUCK SCALES FOR WEIGHING VEHICLES IN MOTION

At the base of the modern scales produced by META there are many years of development and own production of strain gauge load cells, and maintenance of other weighing equipment. The scales at the weight control posts are built based on the dynamic VA-D scale design and are intended to determine the axle load and total weight of cars and trucks on the move.

These scales are used in various industries, in agriculture, and especially, at the weight control checkpoints of traffic police, by authorities of Transport Supervision, as well as in mobile weight control units (a modified version of VA-20D-2 scales is used in those)

The principle of operation of the weights is based on the transformation of the elastic deformation of strain gauge sensors arising under the action of gravity of the vehicle weighed which is converted into analog electrical signals. Such analog electrical signals from the sensors are added up and fed into a microprocessor control unit in which the total sum of the signals is further converted into a digital code. The value of the mass of the weighed vehicle is then stored on a special hard drive.



NAME OF CHARACTERISTIC	WEIGHT VARIANT				
	VA-20D-1	VA-40D	VA-60D	VA-20D-2	VA-20D-4
WEIGHING IN MOTION					
Lowest weight limit (LWL), kg	500				
Highest weight limit (HWL), kg	200000				
Readability (d), kg	10				
Limits of allowable error at the moment of weighing during movement with a speed of no more than 10 km/h: uncoupled vehicle, trailer unit or semitrailer vehicle, trailer, semitrailer in a road train without detaching in the initial verification or calibration (for operation): from LWL up to 35% of HWL inclusively, % from 35% of HWL; higher than 35% HWL % of measured mass	±1.0% (±2.0%)				
Maximum speed of traffic through scales	Unlimited				
Dimensional specifications of load carrier platform, mm, no more	3500×1100	3500×4000	8000×3500 6000×3500	1000×600 (2 in a set)	1000×600 (4 in a set)
Mass of load carrier platform, kg, no more	1500	3000	5000 4000	2×200 (2 in a set)	4×200 (4 in a set)
STATIC WEIGHING					
Lowest weight limit (LWL), kg	200		400	200	
Highest weight limit (HWL), kg	20000	40000	60000	20000	20000
Value of testing interval (e), increment (d)	10		20	10	
Limits of allowable error for initial calibration (operation and after repair), kg: from LWL up to 500e; from 500e up to 2000e; higher than 2000e	± 5; ± 10; -	± 5; ± 10; ± 15	± 10; ± 20; ± 30	± 5; ± 10; -	± 5; ± 10; -
DETERMINATION OF AXLE LOAD ON THE ROADWAY IN MOTION					
Highest measurement limit (HML), kg, no more	20000	40000	60000	20000	20000
Lowest measurement limit of axle load on roadway, kg	500				
Increment, kg	10				
Limits of allowable measurement error for axle load at a speed up to 10 km/h in % of HML upon initial calibration in operation	± 1 ± 2				
Limits of allowable error at a speed between 10 and 20 km/h, % of HML upon inspection in operation	±3.0% ±3.0%				
Limits of allowable error at a speed between 20 and 40 km/h, % of HML upon inspection in operation	±8.0% ±8.0%				
Limits of allowable error at a speed between 40 and 60 km/h, % of HML upon inspection in operation	±13.0% ±13.0%				
Range of speed measurement, km/h	From 1 to 60				
Limits of allowable error, % of measured speed	± 10				
Range of axle bases, m	1,2 – 12				
Limits of allowable error of distance between axles, % of measured distance	±10				



Functions:

- Measures axial loads on the road surface and the vehicle weight while static and in motion.
- Determines the type of vehicle, its speed, and axial distances for weighing in motion.
- Video monitoring and preservation of photographic images of the weighed vehicle in the computer.
- Control over the movement of the vehicle weighed.
- Establishing and maintaining a database of vehicles with the ability to create and print final documents.

Features:

- High accuracy at speeds of up to 60 km /h
- Stability and ease of operation. Thanks to its robust and well thought out design, the scales work perfectly even in the harshest of environments.
- The ease and convenience of weighing thanks to advanced technology. There is no need to use lifting equipment due to the minimal dimensions of the weighing plate made of aluminum alloy.
- Versatility: the scales are suitable for weighing all types of vehicles, irrespective of their size.
- A wide operating temperature range of -40 to +60 C.
- The scale is designed for high intensity work of up to 20,000 vehicles a day.

Advantages:

- Simplicity and ease of maintenance;
- The thickness of the platform is only 28 mm, and it is made of an aluminum alloy;
- Increased protection from the environment with a special function of covering the platform to shelter it from the elements.



Рабочее окно распознавания гос. номера транспортного средства

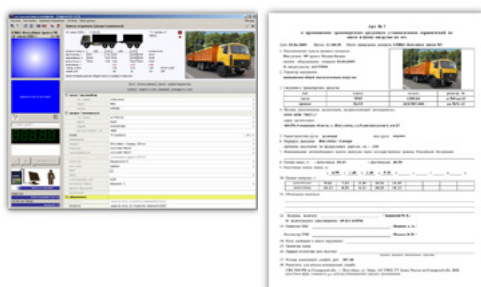

Дата	Время	Пост	Марка автомобиля	Гос. номер	Скорость	Габарит	Общая масса
03.08.2010	14:01:23	М2 "КРЫМ"	DAF 95	К068РР 68	8 км/ч	11,92 м	30,54 т
03.08.2010	14:02:21	М2 "КРЫМ"	Renault	Н004АМ 31	12 км/ч	12,25 м	28,34 т
03.08.2010	14:02:48	М2 "КРЫМ"	ЗИЛ	8023НК 50	19 км/ч	4,46 м	9,42 т
03.08.2010	14:03:03	М2 "КРЫМ"	Volvo	К710ОА 199	9 км/ч	11,87 м	34,58 т
03.08.2010	14:03:23	М2 "КРЫМ"	КАМАЗ	С685ОН 57	16 км/ч	4,02 м	20,66 т
03.08.2010	14:03:44	М2 "КРЫМ"	TATRA	А364АТ 56	23 км/ч	4,51 м	26,84 т

VA-20D-2

Portable truck scales to determine the axle load and total weight of cars and trucks on the move at speeds of up to 60km / h

Two compact load plates with the size of 600 x 1000 mm occupy only a minimum area of the roadway, the construction of the foundation for these scales can be carried out with minimal costs.

This modification of the weights is included in the "Weight control" hardware-software complex.

A more detailed description of system capabilities of the "Weight control" hardware-software complex and its function in the application of VA-20D-2 scales is given in a separate publication titled "Weighing Equipment and Automobile Weight Control Checkpoints" as well as on the website of the manufacturer at: <http://www.meta-moscow.ru/>

VA-20D-1

A load plate with the size of 1100 X 3500 mm.

- Covers 3,500 mm. lanes;
- The accuracy of measurement done by this device is independent of the space which vehicle travels on when it enters the area of the scales.

VA-40D

A load plate, length from 900 to 3500 mm. with the width of 4000 mm.

- The enhanced platform BA-40D scales allow for weighing of road transport with an axle load of up to 40 tons;
- The VA-40D scales cover the entire width of the lane and leave no opportunity for the vehicle to go round the weight control checkpoint area.

VA-60D

A load plate with the size 6000 x 3500 mm or 8000 x 3500 mm.

- Covers the entire width of the lane and leaves no opportunity for the vehicle to go round weight control checkpoint area;
- The accuracy of measurement done by this device is independent of the space which vehicle travels on when it enters the area of the scales.



WEIGHT PLATFORM VPA

Truck scales VPA were designed for weighing commercial vehicles in static mode. The weighing result is displayed on a digital display of a remote control console and on an external repeater display. The truck scales of the VPA model are equipped with automatic zero setting when the scales are activated, an automatic tracking of zero when the weight load on the plate changes due to rain and pollution and a signaling mechanism when there is an overload. The scales can be connected to a computer via a VPA output RS 232 interface for automatic registration of weighing and recording of goods carried. VPAs are supplied in the form of a prefabricated metal platform with a remote control and an external repeater display. The scales can be installed in a special pit with a concrete foundation or on a raised area made of reinforced concrete. The special modular design allows for merging of two VPA weighing platforms for weighing long vehicles (of up to 16 meters).



Functions:

- Automatic registration of axial and per-wheel loads of vehicles.
- Printing out protocols of weight control on the built-in thermal printer of the control panel: the date, time, per-wheel and axial load, and gross vehicle weight.
- Transfer of data from the platform to the control unit over a special communication link.
- Maintenance of a database of measurements by use of dedicated "Weight control" software.
- Reporting on the work of the weight control checkpoint.
- Automatic calculation of the fine for transportation of excessively heavy loads.

Advantages:

- The weighing result is displayed on the digital display of a remote control unit and on an external repeater display.
- Automatic setting of the zero on the scales.
- Automatic tracking of the zero when the weight load on plate changes due to precipitation and/or pollution.
- A signaling mechanism when there is overload.
- Ability to report the output of the scales by use of a special RS 232 interface for automatic registration of weighing results and recording of goods carried.

TECHNICAL SPECIFICATIONS						
NAME	WEIGHT, KG		ACTUAL VALUE OF INTERVAL (D) AND TEST INTERVAL (E) (D=E), KG	WEIGHING INTERVALS, KG	LIMITS OF ALLOWABLE ABSOLUTE ERROR FOR INITIAL CALIBRATION, MPE*, ±KG	LIMITS OF ALLOWABLE ERROR IN OPERATION AND AFTER REPAIR AT AN OPERATING BUSINESS, MPE*, ±KG
	MINI-MUM	MAXI-MUM				
ACCURACY CLASS III (AVERAGE) PER GOST R 53288-2008						
VP-30A	200	30000	10	From 200 to 5000 From 5000 to 20000 Higher than 20000	5 10 15	10 20 30
VP-40A	200	40000	10	From 200 to 5000 From 5000 to 20000 Higher than 20000	5 10 15	10 20 30
VP-50A	400	50000	20	From 400 to 10000 From 10000 to 40000 Higher than 40000	10 20 30	20 40 60
VP-60A	400	60000	20	From 400 to 10000 From 10000 to 40000 Higher than 40000	10 20 30	20 40 60
VP-80A	400	80000	20	From 400 to 10000 From 10000 to 40000 Higher than 40000	10 20 30	20 40 60

NAME PERFORMANCE	DIMENSIONAL SPECIFICATIONS OF LOAD CARRIER PLATFORM, MM, NO MORE	MASS OF LOAD CARRIER PLATFORM, KG, NO MORE
Performance 1	6000x3500x700	3600
Performance 2	8000x3500x700	4600







Comprehensive
security systems

AUTOMATED ACCESS CONTROL SYSTEM **BARRIER**

The stationary electromechanical barricade, the BARRIER-200, designed to protect high-profile facilities of the Ministry of the Interior and the Russian Ministry of Defense from unauthorized entry or passage by vehicles, was developed and put into operation in 2004 by an order of the RF Ministry of Defense. The barricade design was patented.

After the design of the BARRIER-200 was improved, the barricade product line was expanded for equipping garage complexes and parking lots, railway crossings, high risk areas and strategically important facilities.

The main design is a strong steel panel sheathed with rope wires blocking passage, forming a solid system with fortification blocks weighing 12 tons. When an automobile is stopped, the kinetic energy transfers into the work of moving the block and the flexible strain of the barrier panel. The barricades are issued in versions with a passage width of 3.50 and 4.50 m.

In 2009 a new patented design was developed for a two-sided all-purpose barricade to block vehicular traffic in both directions.

The BARRIER-200 barricades were installed at strategically important and socially significant facilities of Russia and protect against unauthorized entry to the facilities:

- Volzhsky Hydropower Plant lock canal in the name of Lenin;
- territory of the Ryazansky Military Automobile Institute;
- main automobile storage bases for vehicular and armored property of the Moscow, Penza and Samara districts;
- territory of the FSI "Volzhsky State Basin Authority of Waterways and Shipping" in Nizhny Novgorod.

ДОСТОИНСТВА:

- Effective protection of the guarded facility from unauthorized entry by vehicles.
- Formidable obstacles for all categories of vehicles.
- Intelligent identification system for vehicles with "friend-or-foe" sign.
- Rapidity of ascent/descent of barrier panel.
- Patented design and technology of energy absorption by a moving automobile up to 61 mJ at a speed of 50 km/h, which significantly exceeds the figures for counterparts.
- 10 years of experience in protecting particularly important facilities of the RF Ministry of Defense and facilities of Russia's Ministries of the Interior and Transportation.
- Licensed fusing technology and anti-corrosion protection with the acceptance of the Customer RF Ministry of Defense.
- Simple and fast assembly at any active facilities without using complex technology and disrupting the protection regime.
- Efficient complete recovery of the barricade panel after a vehicle is detained within 20 minutes from the reserve parts set.
- Barricade panel width from 3.5 to 4.5 meters.

ACCESS CONTROL SYSTEM DOZOR-ANTITERROR

- “Friend-or-foe” identification by the vehicle’s license plate or by a radio frequency ID set in the vehicle.
- Sudden blocking of the entrance to a protected territory in case of the appearance in the observation zone of:
 - a vehicle not identified as friend or foe;
 - a vehicle moving in excess of the established speed;
 - other atypical movement of objects or people.
- Creation of a base of vehicles traveling through with a photographic image record.
- Automatic management with blocking and verification of vehicles traveling to the territory with databases of authorized vehicles.
- Development of reports for the indicated intervals and observation periods for the division officer or facilities manager.

Simultaneous operation of the control system on 16 communication channels ensures the rapidity of data transfer without decreasing the capacity. The protected information exchange protocol with more than one trillion (10¹⁹) combination codes prevents the forgery of a radio frequency ID set for a vehicle. The data encryption capability makes the communication channel interference-proof and protected from unauthorized access. The radio modules that are used provide a communication distance up to 4.5 km.



BARRIER-200

The stationary electromechanical barricade is designed to protect high-profile facilities of the Ministry of the Interior and the Russian Ministry of Defense from unauthorized entry or passage by vehicles. The automated checkpoint based on a movement barricade, Barrier-200, was developed in accordance with a Technical Assignment of the Russian Ministry of the Interior.

The main design is a strong steel panel sheathed with rope wires blocking passage, forming a solid system with fortification blocks weighing 12 tons. When an automobile is stopped, the kinetic energy transfers into the work of moving the block and the flexible strain of the barrier panel. The barricades are issued in versions with a passage width of 3.50 and 4.50 m.

BARRIER-200.01

The mobile assembly version is put together at the site of special events in 30 minutes from individual parts weighing no more than 50 kg, it has an independent power supply, and it does not damage the road surface.

The system design is protected by patent No. 48219 of the Federal Service for Intellectual Property.

The barricades went through acceptance testing by an inter-agency commission made up of representatives of the RF Ministry of Defense, Russia's Ministry of the Interior and the Ministry of Transport, as well as an operational test in Special Police Force work for the city of Togliatti and in the Chechen republic.

The barricade designs were developed in accordance with technical assignments of the RF Ministry of the Interior from 2004.

The BARRIER systems were installed at strategic and socially significant venues of Russia:

- for protection of the Volzhsky Hydropower Plant lock canal in the name of Lenin;
- in the territory of the Ryazansky Military Automobile Institute;
- at the main automobile storage bases for vehicular and armored property of the Moscow, Penza and Samara districts;
- in the territory of the FSI "Volzhsky State Basin Authority of Waterways and Shipping" in Nizhny Novgorod.

BARRIER-200.02

The checkpoint based on a movement barricade, BARRIER-200.02, is designed to close off passage and control the passage area of vehicles with a prohibiting signal light and is used as an obstacle to stop unauthorized passage of a vehicle through the checkpoint of military bases and posts, field parks, in passage zones in the territory of socially significant and high-risk venues, as well as in territories of railroad crossings as additional obstacles to stop unauthorized entry by vehicles to a railway crossing with a red signal light.





TECHNICAL SPECIFICATIONS

Energy-absorbing capability, kJ	22540
Passage width, mm	3300
Platform ascent time from open position to closed, s, no more	8
Power intake of electric motor, kW	0,12
Dimensional specifications of barricade, mm, no more in "Open" position	4350x1500x60
in "Closed" position»	4350x1500x700
Mass of barricade, kg, no more	520

VEHICLE DISABLER IN CASE OF AN INTOXICATED STATE

ALKOZAMOK

Monitoring resource for a vehicle driver's sobriety condition



Area of usage:

- for social transport, on school buses, railway transportation, on metro trains, for special cargo conveyance.

Functions:

- Unambiguous determination of alcohol in exhaled air.
- Audio and visual support of the measurement procedure.
- Disabling of the vehicle's ignition system in the case of detection of alcohol in the exhaled air.

Advantages:

- High degree of accuracy in the measurements.
- Absolute discrimination relative to elements in the vehicle's interior: gasoline, fuel acids, aromatizers, scents.
- Does not require calibration and maintenance.
- Prevents falsification of exhalation.
- Fiscal record without an editing capability.
- Remote delivery of an incident of alcohol in the breath to the control center via a GPRS log-in access channel.



Disabler with the ability to enter the driver's personal data

TECHNICAL SPECIFICATIONS

Trigger threshold, mg/l	0,150
Time for express analysis, s	3
Number of fiscal records in the format "Date-time-number breath-result", no less	2700
Electric supply: from the vehicle's in-vehicle network, V	12,6±20% (24±20%)
Power intake, V, no more	10
Dimensional specifications of the measurement unit, mm, no more	195x80x58
Mass of measurement unit, kg, no more	0,4
Range of operating temperatures, °C	-10 - +40



Police equipment

RADAR SPEEDOMETERS WITH VIDEO RECORDING AUTOSCAN

“AUTOSCAN”, radar speedometers with video recording, are designed for automatic detection of moving vehicles in the monitored zone, the speed measurement of a vehicle’s motion, video recordings of a violation of the speed limit and other traffic rules, observation of events on a monitor, and processing, storage and playback of video recordings on the monitor screen. The speedometers will be used by Federal Traffic Safety Administration employees in highway patrol service.



Functions:

- Remote speed measurement of vehicles moving in the flow of a selected direction with high speed.
- Automatic video recording of speed violators if the established speed threshold (20-250km/h) is exceeded and video recording in the one-time manual speed measurement mode with a marking on the still shot of the date, time, and speed.
- Capability of storing information from the map files on the master control with a subsequent printout.
- Regulation of the number of still shots in the clip and the time interval between shots, depending on the traffic situation.
- Review on a built-in monitor of the recorded information, digital zoom of selected shots.
- Vehicle speed measurement in manual and automatic modes both for individual and for vehicles moving in a group exceeding the speed of traffic flow.
- Speed measurement both in a stationary and in a moving patrol vehicle mode.
- Vehicle selection according to direction of their movement (speed measurement of only on-coming or only passing vehicles).
- Visual image on the photo-still display of traffic conditions with information about the date, time, and speed of moving vehicles, with the capability of video recording at the operator’s command.
- Record of single shots; capability of reproducing the recorded violation of driving regulations both with still shots and with video clips.



AUTOSCAN-M

Advantages:

- Measurement of vehicular speed both of individual and of vehicles moving in a group exceeding the traffic flow speed in an automatic mode.
- Capability of establishing a monitored vehicular traffic direction - discrimination (approaching and leaving).
- Automatic video record and delivery of an audible signal if a vehicle exceeds the established speed threshold.
- Visual image on the display of still shots of traffic conditions.
- Photo mode.
- Capability of reproducing the recorded violation of driving regulations both with still shots and with video clips.
- Capability to connect a modem for the transferring of data about a violation.
- Capability of identifying government license plates.



AUTOSCAN-MV

Advantages:

- Capability of storing up to 1360 color shots in memory.
- Capability of storing information from the map files on a PC with a subsequent printout.
- Vehicle selection for direction of their movement: speed measurement of only on-coming or only passing vehicles.
- Capability of recording single shots (photo mode).
- Capability of reproducing the recorded violation of driving regulations both with still shots and with video clips.
- Prevention of the unauthorized removal of a recorded driving violation by an operator and ensuring the logging of work from the program.

TECHNICAL SPECIFICATIONS

	AUTOSCAN M(V)	AUTOSCAN M	AUTOSCAN P	AUTOSCAN S
Power supply, V, no more	from 10 to 16	from 10 to 16	12	220
Power intake, W, no more	100	100	100	1000
Range of speed measurement, km/h	from 20 to 250			
Allowable error limit for speed measurement in a stationary mode, km/h, no more	+1	+1	+2	+2
Allowable error limit for speed measurement in a motion mode, km/h, no more	+2	±2	±2	±2
Operational frequency of emission, GHz	24,150±0,1			
Alignment of record, s	From 0.1 to 5 (step 0.1)	from 5 to 60 (step 5)	от 5 до 60 (шаг 5)	от 5 до 60 (шаг 5)
Speed of record, shots/s	6			
Range of operating temperatures, °C	from 0 to +60	from 0 to +60	from -20 to +50	from -40 to +50

ANALYZERS OF ETHANOL VAPOR CONCENTRATION IN EXHALED AIR AKPE

The AKPE-01 devices are a medical measurement resource and serve for the quantitative measurement of alcohol content in exhaled air. By the Order of Russia's Roszdravnadzor No. 280-Pr/11, the AKPE-01 device was accepted for use in order to establish the degree of intoxication, entered into the stage registry "Medical Technology Products" FSC 2011/09984. The principle of the device's work is based on the spectrophotometric method of determining ethanol vapors. AKPE-01 possesses total selectivity in relation to substances interfering with the determination of ethanol in exhaled air. The AKPE-01 has been produced commercially since 1994 and is the first and so far the only, having no counterparts, Russian resource for measuring the ethanol content in exhaled air. The process of discerning alcohol in the device is completely automated and prevents the possibility of error or falsification of findings. The initial conditions are established before each measurement with neutral air cleared of ethanol with a special filter.

During the release of the device, the product line was significantly expanded; modifications of the AKPE were introduced with the video recording of the measuring process, and portable devices were introduced in a compact frame with a built-in printer.

In order to improve the accuracy of the readings, the element base was modernized to exclude error from non-measured elements. An improved version of the software was developed, as well as operational indicators as part of the expansion of the operation temperature range.

For measurement support of the alcohol analyzer, GSBS-META-02 devices were issued.

Also, the META company developed and put into operation the vehicle disabler in case of an intoxicated condition, ALKO-ZAMOK, designed to monitor a driver's sobriety state.

Approved for usage by Roszdravnadzor Order No. 380-Pr/11 from 2/2/2011.

Recommended for usage by the Federal Traffic Safety Administration of the Russian Ministry of the Interior



Functions:

- Automatic calibration of the measuring channel before each measurement.
- Monitoring of the duration of the breath.
- Monitoring and recording of an interruption in the breath and an incomplete breath with an image of the violations on the display.
- Measurement of the concentration of ethanol vapors in exhaled air with a representation of the results on a liquid crystal alphanumeric display of 128x32 pixels.
- Involuntary sample selection for express analysis.
- Storage of up to 4,000 measurement results with a date and time reference in the fiscal memory.
- Printing of the measurement results report on the built-in printer. The report contains the device's serial number, date and time of the measurements, date of the measurement verification, and the value of the measured concentration of ethanol vapors in exhaled air.
- Submission of a block of measurement results to the computer.

Advantages:

- Objectivity of evaluation: excludes an inaccurate result in cases of recorded alcohol in the mouth cavity, reports an interruption in breathing or insufficient breath force.
- Monitoring of surrounding air: automatically monitors the alcohol contents in the surrounding air and in the sampling system.
- Printing of the record: the record contains measurement results, date, time, device number, and record number. There is a fiscal record of the results.
- Productivity: allows for up to 80 examinations in one hour.
- Accuracy: the entire operation period does not require calibration, and the stability of the measuring characteristics is stored without the use of control gas mixtures.
- Capability of connecting video cameras that make it possible to have a video recording of the medical examination with video of the examined image in the video registry memory.



Hand-held analyzer of ethanol vapor concentration

AKPE-01.01



AKPE-01.01-01

**Small-scale analyzer of ethanol vapor concentration with internal 12V power for work at mobile posts**

AKPE-01.01M

AKPE-01.01M-01
with built-in keyboard**Portable analyzer of ethanol vapor with independent and internal power supply. Allows for express analysis with involuntary selection of an air sample through a funnel for a no-contact express analysis. Issued in three versions: with keyboard, without keyboard, and with keyboard and built-in printer.**

AKPE-01M

with keyboard and external printer



AKPE-01M-01

with printer



AKPE-01M-03

with keyboard and built-in printer

**SPECTROPHOTOMETRIC ALKOTESTER 02****Advantages:**

- Increased accuracy.
- Does not require calibration for 12 months.
- Reasonable price



NOVELTY

TECHNICAL SPECIFICATIONS

Display	Alphanumeric liquid crystal display
Range of calibrated readings, mg/l	0-1,500
Electric supply	Built-in battery 3.6 V 2.2 A* hour
Mass, kg	0,4
Overall dimensions, mm	200x80x50
Conditions of operation: temperature of surroundings	From -10 to +40

TECHNICAL SPECIFICATIONS				
	AKPE-01.01, AKPE-01.01-01	AKPE-01.01M AKPE-01.01M-01	AKPE-01M, AKPE-01M-01, AKPE-01M-02	AKPE-01M-03
Range of measurements of large ethanol vapor concentration in exhaled air, mg/l			from 0 to 1.500	
Range of readings, mg/l from			0 to 5.000	
Limits of allowable absolute error in the range of 0-0.200 mg/l			± 0.020 mg/l	
Limits of allowable relative error in a range higher than 0.200 - 1.500			± 10 %	
Time of measurement after sample selection, s			no more than 5	
Time of preparation for operation after turning on at the surrounding air temperature (20 ± 5) °C, min		no more than 10		no more than 3.5
Time of preparation for operation after measurement at the surrounding air temperature (20 ± 5) °C		no more than 60 s		no more than 20 s
Time interval of analyzer operation without adjustments to readings, no less			12 months	
Electric supply	—AC network with voltage (220±22) V, frequency (50±1) hz —DC power supply with voltage (12±2) V	—DC power supply with voltage (12.6±2) V; —in-vehicle network (12.6±2) V	—in-vehicle network (12.6±2) V; —built-in accumulator battery; —network supply and charge (5±0.25) V;	
Number of measurements in analyzers without recharging the accumulator		-		no less than 250
Range of surrounding air temperature, °C		from 0 to 40		from minus 10 to plus 40
Relative humidity of surrounding air at a temperature of 25 °C, %			no more than 98	
Range of atmospheric pressure, kPa			from 66.6 to 106.6	
Dimensional specifications, mm, no more	440x135x270	275x215x95	195x80x50	223x78x68
Mass, kg, no more	5,5	3	0,4	0,5
Power intake, VA, no more: in warming-up mode in operating mode	60 10	60 10	5 0,5	10 2,5

LICENSES AND CERTIFICATES OF THE ANALYZER OF ETHANOL VAPOR CONCENTRATION AKPE 01.01



Entered into the State Registry of Medical Technology Products, Registration Certificate No. FSR 2011/09984



Winner of the contest of Russia's Ministry of the Interior Traffic Safety Department, «Safe Road» in the category: «Best Device» for examining the alcoholic intoxication condition and the competition winner of the program «100 Best Products of Russia».



Awarded the gold medal of the international quality mark «For High Quality. New Millennium».

INDICATORS OF ETHANOL IN EXHALED AIR **ALKOTESTER**

The ALKOTESTER alcohol indicators have been commercially produced since 2000, and they are designed to detect alcohol vapors in exhaled air in the monitoring of drivers' sobriety and in other necessary situations for revealing persons suspected of consuming alcoholic drinks.

During the release of the device, META developers created a new frame for the device and introduced an independent power supply. Also, errors in inserting a sample into the detector are prevented through the introduction of a blowing chamber with a mouthpiece.

In 2012, thanks to high-quality production, commercial output was able to be initiated for the ALKOTESTER spectrophotometric devices on the basis of the work of the spectrophotometer, which significantly increased the accuracy of measurement and decreased the expenses for device maintenance.

ALKOTESTER 01

Advantages:

- Increased accuracy of determining the alcohol content in a body with the exhaled air.
- Reliability and ease of use.
- Warning of an interruption in breathing and insufficient force of breath.
- Light and audible alarm for taking a breath sample.
- Monitoring and alarm of alcohol vapors in the surrounding air of closed premises.
- Independent power supply with a life of 36 hours of continuous operation.
- Economy mode and indication of the remaining life of the power supply.
- Electronic calibration of sensitivity for text mixtures of the calibrator.

ALKOTESTER 01.01

with accumulator battery

ALKOTESTER 01.01B

with standard battery

Advantages:

- Successful blend of compactness and functional capabilities.
- Reasonable price
- Reliability and ease of use.
- Warning of an interruption in breathing and insufficient force of breath.
- Light and audible alarm for taking a breath sample.



ALKOTESTER 01



ALKOTESTER 01.01



TECHNICAL SPECIFICATIONS

	ALKOTESTER 01	ALKOTESTER 01.01	ALKOTESTER 01.01B
Display	Alphanumeric liquid crystal display	Digital LED indicator	Threshold LED indicator
Range of calibrated readings, mg/l	0-1,500	0-1,500	0-1,500
Electric supply:	built-in accumulator 3.6 V 1.4 A *hour	built-in accumulator 3.6 V 0.3 A *hour	Battery 1.5 V, 2 pieces
Mass, kg	0,5	0,1	0,1
Overall dimensions, mm	200*80*450	120*46*22	120*46*22
Conditions of operation: temperature of surroundings, °C		from +1 to +40	

SOFTWARE PACKAGE FOR AUDIO AND VIDEO OBSERVATION

FOR THE TRAINING AND ACCEPTANCE OF PRACTICAL QUALIFICATION EXAMS TO OBTAIN THE RIGHT TO DRIVE

EXPERT-M.4

The EXPERT-M.4 hardware and software package with a hard disk drive is designed for audio and video observation for the roadway, monitoring/measuring devices, main and supplementary apparatuses for driving a vehicle, activities of the examinee and examiner, and also for registering and storing obtained information during a practical exam to receive the right to drive.

An image from all video transmitters in real time is continuously delivered to the video camera, produced on the monitor and automatically put on the camera's memory card. Audio information from the exam enters the video camera through a built-in microphone, which is also automatically put on the memory card. Power supply of the entire set comes from the car's in-vehicle network through the cigarette lighter.



Functions:

- Record of images in real time.
- Combination of several images in one picture obtained from the video cameras.
- Audio record of exam.
- Automatic recording of mistakes allowed and penalty points on the monitor screen.

Advantages:

- Synchronous record on one information medium from the video cameras.
- Storage of settings and video material in energy-independent memory in the absence of a power supply.
- Password protection against removal and adjustment of information.
- Storage of information on a hard disk drive up to 1,000 GB or CF and SD cards.
- Visual monitoring of the performance of the equipment when a monitor is available.
- Volume of recorded information from 2 to 192 hours, depending on the memory capacity.
- Equipment has a water-proof and vibration-proof frame.

The software enables:

- A search for a record according to date and time.
- Review of recorded clip at various playback speeds.
- Advanced search for needed information according to marks on the video record.
- Stop-frame function.



TECHNICAL SPECIFICATIONS

Power supply of the recording device, V	from 12 to 30
Current consumption Max, mA	400 (version from CF or SD) 600 (version from HDD 2.5")
Input video signal, V	0,8 – 1,5
Input audio signal, V	0,7 – 1,4
Input resistance, Ohms	75
Output signal, V	1,2
Output audio signal, V	1,4
Output resistance, Ohms	75
Capacity, GB	Up to 1000
Permission for video record, points	720x576 and 360x576 (25k/s) 720x288 and 360x288 (<25 k/s)
Speed of audio stream, Kb/s	64
Speed of frame recording/s	From 1 to 25
Operating temperature, °C	-40...+70
Dimensional specifications, mm no more	140x190x60
Mass, kg, no more	0,15

HARDWARE AND SOFTWARE PACKAGE FOR AUDIO AND VIDEO OBSERVATION FOR A TRAFFIC SITUATION

EXPERT-M.2

Expert-M.2, a hardware and software package for audio and video observation for a traffic situation, is designed for round-the-clock observation and recording of video information and telemetry for a traffic situation and the ac-

tions of the violator and inspector in the patrol vehicle cabin. The video camera for observation of the roadway is installed on the rearview mirror, and the observation video camera for the actions of the Road Patrol Service officer is installed on the dashboard.

The video recorder is installed in the vehicle cabin with the help of support brackets included in the delivery package with vacuum cushions that are secured to any glass of the vehicle.

Power is supplied to the video recorder from a power supply unit from the delivery package.



TECHNICAL SPECIFICATIONS

Power supply of the recording device, V	+12V nominal, possibly from 6 to 18 V.
Current consumption Max, mA	400 (version from CF or SD) 600 (version from HDD 2.5")
Current consumption with video cameras Max, mA	600-1000 (with the connection of 2 cameras)
Input video signal, V	0,8 - 1,5
Input audio signal, V	0,7 - 1,4
Input resistance, Ohms	75
Output signal, V	1,2
Output audio signal, V	1,4
Output resistance, Ohms	75
Capacity	Depending on the medium capacity
Permission for video record, points	720x576, 720x288, 360x288
Speed of audio stream, Kb/s	64
Operating temperature, °C	-10...+50
Dimensions SxGxV, mm	95x150x60 (ver. HDD), 95x150x40 (ver. CF or SD)

The software enables:

- A search for a record according to date and time.
- Review of recorded clip at various playback speeds.
- Stop-frame function.

Functions:

- Record of images in real time.
- Synthesis of images obtained from the video cameras.
- Storage of information on a hard disk or the CF and SD information medium type.

Advantages:

- Presence of energy-independent memory for storage of values and video material in the case of a sudden disconnection from the voltage network.
- Password for removal and adjustment of information.
- Visual monitoring of the performance of the equipment.
- Volume of recorded information from 2 to 192 hours, depending on the memory capacity.
- Capability of connecting the video recorder to the PC for review and processing of recorded video information using software.



AUTOMATED «AUTODROME-META»

- PREPARATION OF DRIVERS FOR CATEGORIES "B", "C", "D",
- INCREASE OF QUALIFICATION AND ACCEPTANCE OF FIRST STAGE OF PRACTICAL EXAM
- DESIGN OF AUTODROMES
- EQUIPMENT INSTALLATION
- PERSONNEL TRAINING



Automated AUTODROME-META is designed for the training and passing of practical qualification exams to obtain the right to drive.

AUTODROME-META is an intelligent system for training drivers and passing the qualification exams.

AUTODROME-META is stationed in the territory of about two hectares with level, uniform asphalt concrete pavement and equipped with sections for 12 exercises in accordance with the approved method of conducting exams.



The operating principle of the "Autodrome-Meta" is based on the use of dashboard video recorders that identify markers and record instances of the vehicle's wheels straddling the guide lines.



Functions:

- Recording of the results of test exercises according to a specially developed method in conditions that are very close to real road traffic.
- Processing of the result and delivering the report of the exam without the examiner's participation.
- Recording of the time for executing the exercises and mistakes in performing the control exercises: crossing the guide lines, rolling back of the vehicle on an incline, shifting gears and hand brake, and other actions of the driving candidate.
- Control and monitoring of the movement of vehicles around the autodrome in order to provide safety.
- Acceptance and transfer of operation information and student mistakes through the radio channel on the control center server.
- Automatic control of the correctness of the data transmitter system and metrological ensuring of accuracy of the recording of mistakes permitted during the test exercises.
- Protection of the system from unauthorized access and the falsification of results from test exercises.

Advantages:

- High reliability and accuracy of the recording of mistakes from exercises by means of video monitoring of an incident of crossing the guide line.
- A significant decrease in the cost of autodrome equipment by means of using video recorders identifying the control mark of the "START" and "STOP" lines and lines for proper parking.
- A reduction of volumes and terms of construction/installation work in comparison with similar autodromes on the basis of mechanical data transmitters.
- A reduction of operational expenses and an increase of reliability of the autodrome equipment operation.
- The Autodrome-Meta does not contain mechanical crossing sensors and permits mechanized clearing of snow from the area.
- The absence of mechanical sensors for crossing the guide lines makes it possible to use the equipment year-round without decreasing the accuracy of recording the mistakes in any climate zones of the Russian Federation.
- Capability of timely resetting of the program for passing the exam with the use of normative technical requirements for the automated autodrome.



Автомобили	Состояние	Баллы	старт	горка	пеш. пер.	крут. покл.	светофор	змейка	гараж	Ж-д	Парк	раз. гит.	ввар. ост.	стойл.	Датч.
№ 001 (УАЗ-439)	Не разрешено [Парковка]	---													
№ 002 (ВАЗ-2107)	Разрешено [Зеркала]	100													
№ 003 (КАМАЗ)	В движении [Остановка]	94	✓	✓	-6										
№ 004 (ВАЗ-2107)	В движении [Остановка]	78	✓	-5	-5	-7	✓	✓	-2						-3
№ 005 (ЗИЛ)	Сдал	88	✓	✓	✓	✓	✓	✓	-5	-5	✓	✓	✓	✓	-2
№ 006 (ПАЗ)	Не сдал [Дискв.]		✓	-10		-3	X								
№ 007 (ГАЗ-24)	Разрешено [Парковка]	---													
№ 008 (ГАЗ-24)	Отключено [Парковка]	---													

For simulation of real traffic conditions at the autodrome, it is equipped with:

- "intersection" area;
- "pedestrian crossing" area;
- "railway crossing" area;
- "overpass" area;
- road signs, traffic lights and guide lines..

AUTODROME-META

- Guarantees the highest level of objectivity in evaluation and accuracy of the recording of mistakes in the complete set of mandatory exercises and specialized tasks.
- Metrologically provided by laser pointers for optic recording of the approach of wheels to guide lines at an allowable distance.
- Initial driving training with comments and prompts of an electronic examiner.
- Development of the habits of a first class driver according to the dashboard monitor of side video cameras.

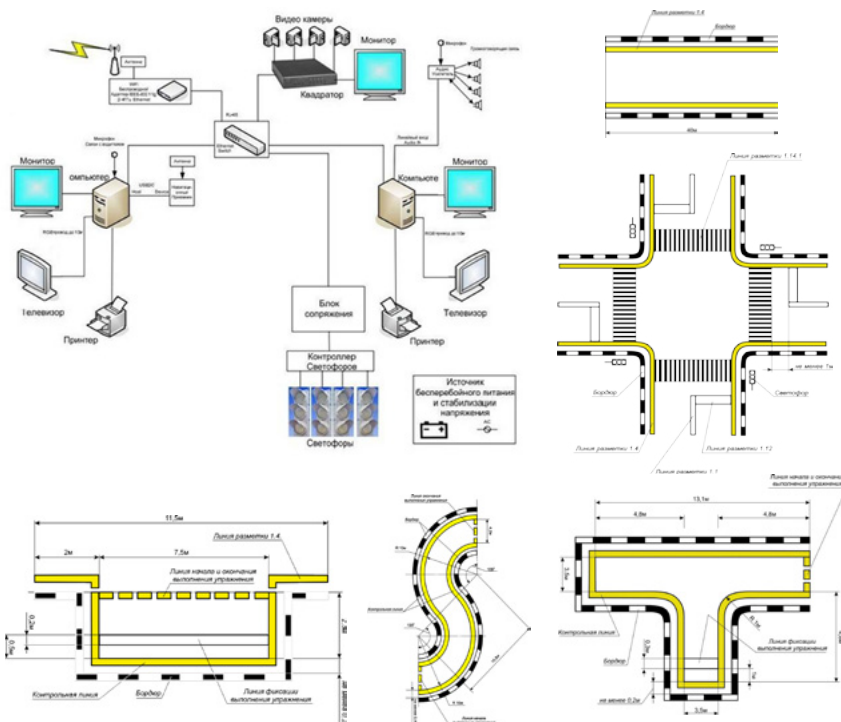







Model verification instruments

GENERATORS OF ALCOHOL-AIR MIXTURES **GSVS-META-02**

The GSVS model generator of alcohol-air mixtures was developed and brought to production in 2003. GSVS is designed to prepare ethanol gas mixtures used in conducting the verification and testing of analyzers of ethanol vapors in exhaled air.

- Complete simulation of a person's exhalation.
- Container for the ethanol solution with temperature sensor and electric heating unit.

GSVS-META-02



GSVS-META-02 S



GSVS-META-02 M



ALL-PURPOSE CALIBRATION BOARD

The all-purpose calibration board is designed to conduct periodic calibration of the alcohol indicators of the ALKOTESTER-META to various modifications and the small-scale leak detectors TM-META.

- The board is connected to the diagnostic outlet of the ALKOTESTER-META indicators or the leak detectors with cables included in the delivery supply.



Electric supply of the board comes from an external power supply BPN-A included in the delivery supply of the board

TECHNICAL SPECIFICATIONS

Power supply voltage, V	14-20
Current consumption, mA, no more	250
Dimensional specifications, cm, no more	140x80x40
Mass of board, kg, no more	0,20

SPL-META, GONIOMETRIC UNITS OF THE 3RD CATEGORY

The SPL-META goniometric units are designed for the assignment and simulation of the steering wheel positions when conducting verification and regulation of the devices for measurements of the total play in the steering system of vehicles. In recent years, in connection with the tightening of requirements for the production and certification of calibration equipment, the device's design was changed: the element base was renovated, which made it possible to greatly increase the accuracy of the device and expand its range of measurements. The operation of the measuring system of the SPL-META 3rd category goniometric units lies in the simulation by the units of steering wheel positions of vehicles at the assigned corner units according to the electronic readout. The measurement of the assigned turning angle is conducted by an electric converter of angular rotations.

TECHNICAL SPECIFICATIONS	
Range of turning angle simulation, ...°	±120
Limits of allowable absolute error of turning angle simulation, ...°	±5
Resolution of the turning angle image, ...'	3
Scale graduation value for turning angle, ...°	5
Electric supply of the device is from the power supply unit	12 V, 0.5 A
Dimensional specifications of the frame, no more, mm	400x400x550
Dimensional specifications of the terminal, no more, mm	160x85x50
Mass of the frame, no more, kg	9
Mass of the terminal, no more, kg	1
Conditions of operation: Working range of temperatures, °C relative humidity of the air, no more, %	5 - 35

UVS, WEIGHT-MEASURING DEVICE

The UVS is designed for the verification of small-scale hand-held vehicle scales for wheel and axle weighing.

Advantages:

- High degree of accuracy in the measurements.
- Measurement results are displayed on the liquid crystal indicator.
- The device can work in two modes: measurement mode and calibration mode

TECHNICAL SPECIFICATIONS						
NAME OF DEVICES UVS-X-N	LOWER WEIGHT LIMIT, KG	UPPER WEIGHT LIMIT, KG	VALUE OF TESTING DIVISION AND RESOLUTION E=D, KG	LIMITS OF ALLOWABLE ERROR		
				INTERVALS OF WEIGHING	FOR INITIAL CALIBRATION, ±KG	IN OPERATION, ± KG
YBC-10-1	40	10000	2	From Lower Weight Limit to 500e inc.	±2	±2
				Higher than 500e to 2000e inc.	±2	±4
				Higher than 2000e	±4	±6
YBC-20-1	100	20000	5	From Lower Weight Limit to 500e inc.	±5	±5
				Higher than 500e to 2000e inc.	±5	1±0
				Higher than 2000e	±10	±15
YBC-30-1	100	30000	5	From Lower Weight Limit to 500e inc.	±5	±5
				Higher than 500e to 2000e inc.	±5	±10
				Higher than 2000e	±10	±15

ETO-2, MODEL TELECENTRIC LIGHT

The model telecentric light, designed for calibration and verification of the measuring device for IPF headlight beam performance during its operation, was modernized according to the following indicators:

- Reworked plan for the stabilization of the current for the light bulb for improving performance.
- A crosshair was used for the continuous, more precise measurement at one point of the light circle, which made it possible to increase the measurement accuracy.
- In accordance with standard requirements, a test point for turn signals was introduced.
- Improved software for the device.

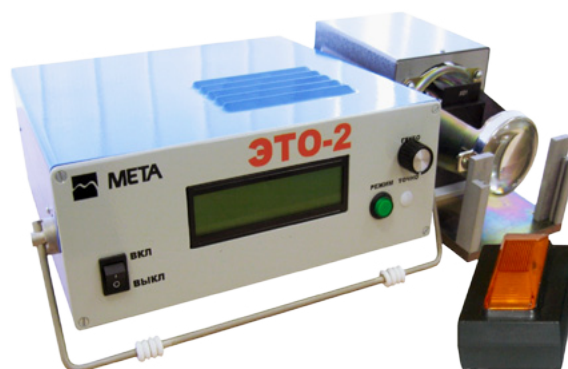

TECHNICAL SPECIFICATIONS

Setting range of calibrated values for the strength of the emitted light, kd	30-1000; 1000-2000; 5000-10000; 10000-30000
Limits of allowable value of relative error for light strength, %	± 8
Adjustment range of voltage, V	12, ±5%
Frequency of turn signal flash, hz	1,0 ; 1,5 ; 2,0
Limits of allowable value of absolute error for turn signal flash, hz	±0,1
Power supply voltage from the AC current network with a frequency of (50±1) hz, V	220±22
Power intake, VA, no more	300
Dimensional specifications, mm, no more:	
lighting unit	236x107x120
turn signal unit	85x125x70
stabilized power source	280x270x140
Mass, kg, no more:	
lighting unit	2,5
turn signal unit	0,5
stabilized power source	5

TALISMAN, MONITORING SYSTEM FOR PERSONNEL AND ACCESS CONTROL

GLONASS/GPS, electronic monitoring system is designed for observation of personnel with satellite navigation.



Electronic monitoring of the work and recreation modes of the supervised group of people: employees of a high-risk business, drivers of vehicles for inter-city hauls, corporate clients, businesses with dangerous work conditions and increased risk.



Electronic monitoring of health condition for employees of police departments, the Ministry for Emergency Situations, and the Ministry of Defense.



Electronic monitoring and access control for business personnel.

The TALISMAN system includes:

- Monitoring server for acceptance of navigation system coordinates and alarm messages from monitored facilities on the GSM communication channel, cable lines, and radio contact.
- Mobile terminal for the transit of messages and special signals between the monitoring server and individual transmitter TALISMAN
- Retransmission unit for the transit of messages and signals from TALISMAN in closed premises without signal access of the satellite navigation GBS/GLONASS and GSM network.
- Personal transmitter TALISMAN (bracelet).

Functional capabilities of the TALISMAN monitoring system:

- Monitoring of the movement of personnel in an open area and zoning for permitted and forbidden premises for personnel access.
- Overseeing of the health condition and working ability of the personnel in open areas and in closed, including underground facilities and transport means.
- Overseeing of the movement of personnel and compliance with the regulations and guidelines for access to forbidden and permitted zones of the facility.
- Storage of the history of the movement pattern and work and recreation modes of the personnel, including transportation drivers.
- Acceptance of urgent instruction commands from the head (leader) and submission of alarm messages:
 - battery class
 - about the absence of movement of a supervised individual
 - unauthorized approach of persons
 - breach of movement corridor
 - breach of perimeter;
 - exit from monitoring zone;
 - breach of the band's integrity and opening the TALISMAN bracelet;
- Emergency call button.
- Tracking of daily living activity characteristics with a set interval.
- Tracking of movement characteristics and presence in the monitored zone by cell phone.
- Built-in movement sensor.
- Management of tracking system protocols.

Advantages:

- Miniature size and little mass.
- Low energy consumption.
- Waterproof casing of the transmitter allows for a visit to the sauna and swimming pool with submersion up to 30 m.
- Built-in battery with a life of 3 years.

ELECTRONIC MONITORING SYSTEM FOR PATIENTS

An electronic monitoring system for people under supervision (children, elderly people, patients, etc.) is designed for continuous, round-the-clock receipt and identification of signals from transmitters and beacons/retransmission units. It is used for the control of the presence and movement in a premises or a set territory, as well as for the reporting of incidents of removal from the hand and/or damage to the transmitters or other breaches.

The personal TALISMAN transmitter is worn on the arm or leg of the supervised person. TALISMAN makes it possible to submit and receive information by means of mobile and stationary retransmission units.



Браслет электронного мониторинга больных

The system provides:

- monitoring of the location and movement of supervised persons in the perimeter of a monitored section, and it also receives, stores, and submits alarm messages about a breach of the monitored section and perimeter boundaries of the given configuration;
- monitoring of the presence of a supervised person in the perimeter of a monitored section in real time;
- timely warning of a breach of the boundary perimeter of a monitored section and
- entrance into a forbidden area of the monitored section by a supervised person;
- timely monitoring for a breach of the band's integrity and clasp of the TALISMAN;
- additionally - any information about the health upon connecting the supplementary sensors in the TALISMAN (temperature, pulse, blood pressure, body movement (hand)).

Functional capabilities:

- Transfer of information on the verification of supervised persons with TALISMAN.
- Monitoring of the movement and integrity of the casing of the beacon/retransmission unit.
- Monitoring of damage to the TALISMAN.
- Transfer of information on the integrity of the TALISMAN band, opening of the clasp and casing of the TALISMAN.
- Monitoring of the TALISMAN within a radius of up to 15 m with the capability of, programmatically or through a special interface, setting various radii of the TALISMAN's supervision zones.
- For expansion of the monitored zone, the capability of setting the beacons/retransmission units is provided.
- Transfer of alarm messages to the server, and then to the terminal of the driver or leader of the supervised facility.

Advantages:

- High cryptographic integrity.
- Interactive interface.



GEOTRANS, TRANSPORTATION MONITORING SYSTEM

Purpose:

- Global monitoring of a corporate client's transport in the area of Russia and the CIS.
- Monitoring of the conveyance of special freight and special squads with two-way communication channels of the board and control station.
- Passenger conveyance, school buses with registration and submission of signals of health, intoxication, and work and recreation modes of the drivers.
- Multi-channel audio and video recording of road conditions, the drivers' actions, and incidents in the vehicle's passenger cabin with the submission of photo images along an alarm signal to the monitoring server on the GSM channel. Storage of information on a hard disk drive of the "black box" in a compact form with protection against forgery and removal.
- Monitoring of the movement and technical condition performance according to security requirements. Recording and storage of information on the haul, speed, fuel consumption, operation modes, and compliance with the route job, speed limit, and road safety rules.
- Vocal two-way communication of the board with the dispatcher along the GSM communication channel. Reports on the condition of the special freight, breaches of the perimeter by the vehicle, and the condition of the locks. Monitoring of access to protected zones by the vehicle.



METKA, GLOBAL MONITORING SYSTEM FOR THE MOVEMENT OF FREIGHT IN THE TRANSPORTATION SPACE

Monitoring of the movement and temporary storage of freight in warehouses and container sites on the basis of electronic "marks".

Escort of freight and containers "from door to door" by means of METKA electronic monitoring along satellite navigation signals.

Three registration categories for freight and valuable property in storage and movement:

- passive two-level RFID-mark with an activity radius of 10 meters;
- active RFID-mark with an activity radius of 1000 meters;
- active RFID-mark with a GSM communication channel and satellite navigation receiver with an unlimited activity radius.

Functional capabilities:

- registration and storage of movement route;
- registration and submission of relevant information about the condition of freight in the container: temperature, integrity of locks, condition of sensors for the perimeter and enclosure, etc.
- monitoring of the performance of the movement sensors for freight and freight containers: acceleration-deceleration, bearings, pitch.



INTEGRATED SECURITY SYSTEMS

Comprehensive protection of the facility, monitoring of life necessities characteristics, supervision of environmental and fire safety of the facilities.

An intelligent protection system for facilities from unauthorized entrance of violators, zoning of facilities by personnel access category, and supervision of movement of marked freight and valuable property within the facility's perimeter.

Комплексная защита объекта, мониторинг параметров жизнеобеспечения, контроль экологической, пожарной безопасности объектов.

- Protection of the perimeter by distributed sensors.
- Video observation and recording of violations of the perimeter and passage zones.
- Blocking of unauthorized entry by personnel and vehicles.

Monitoring of life necessity characteristics for the facility:

- supervision and analytical consideration of the consumption of heat and electric resources by the facility;
- monitoring of wastewater disposal and environmental safety of the facility;
- supervision and analytical consideration of the economic security of the facility's business operations.



GENERAL PURPOSE MOBILE PRE-ENGINEERED BUILDINGS

Pre-fabricated modular buildings, living facilities, work areas and trade studios. Warm, environmental, safe, comfortable, and affordable — from 250 thousand rubles.

Purpose:

- Pre-fabricated modular hotels Capsule of economy class, comfort, luxury.
- Construction rotational camps;
- Multi-story pre-fabricated buildings.
- Mobile unit offices of the technical inspection station operator;
- Movable weight check posts;
- Movable checkpoints for field parks;
- Mobile police posts;
- Mobile headquarters for Ministry of Emergency Situations, armed forces, and rapid response units;
- Medical stations;
- Rotational modules.



Advantages:

- Wide variety in usage: modular buildings can be for a residential or commercial purpose.
- Excellent comfort: standard hotel module with a size of 5050x2350x2500 mm, equipped with two comfortable beds and a separate bathroom with a shower.
- Individual design and interior design, original design with a large selection of finishing materials and color layouts, possible construction of one-story and two-story modular building complexes.
- Safe and environmentally clean finishing materials: medium-density fiberboard, wood structures, Finnish roofing.
- Maximum usage of space for necessary, vitally essential habitation conditions.
- Economic LED-based lighting and aesthetic lighting enables a reduction in expenses by 5 times.
- Does not require lengthy construction work; construction of one modular building takes several days.
- Economy in transportation:
- In non-assembled condition, the capsular building can be shipped by light-duty freight transport.
- For shipping of assembled mobile pre-fabricated buildings, no special technology is needed; it can be shipped in a trailer with only an automobile.

Additionally, at the request of the Capsule customer, it is equipped with:

- An efficient system for ventilation, air conditioning, and climate control in the premises;
- Informational and telecommunication equipment: access to the Internet, IP-tv, etc.
- Economic heating with heat recuperation: only 500 W for heating the building at a temperature of minus 30°C, and the energy supply from solar batteries with accumulators on the basis of Li accumulators.
- Independent water supply systems and wastewater disposal systems.



AWARDS AND ACHIEVEMENTS



META — Winner of the All-Russian competition “Safe Road” of Russia’s Ministry of the Interior Traffic Safety Department and Stop newspaper in the category “Best Resources of Vehicle Technical Diagnostics”, and in the category “Driver Examination for Alcohol Intoxication”



1st degree certificate for the contest Gold medal of the Siberian Trade Fair AUTOSIB-2002 for applicability and potential relevance on the modern market of gas analyzers “Autotest-SO-SN-SO₂” 2002



International certificates and gold medals of the US Chamber of Commerce and Industry “For High Quality. New Millenium”.



Gold medal in the international exhibition EXPO-91



2nd degree certificate of the Russian agro-industrial exhibition “Gold Autumn” for the development of a set of devices for monitoring the technical conditions of self-powered machines. 2006.



Winner’s certificate in the category “Brand-olymp” of the contest “Company of the Year. Best businesses of the Samara district-2004”



Certificate of the “100 best goods of Russia-2003”. Analyzers of ethanol vapor concentration АКРЕ-01

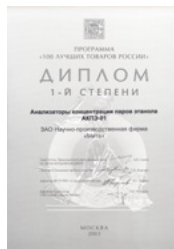

Certificate of the “100 best goods of Russia-2003”. Small-scale general purpose braking exhibits STM-6000



Certificate on the acquisition of a quality mark for the measurement unit for light transmission of glass, “Tonic,” at the second international exhibition of measurement and testing equipment resources “Metrology-2007”



2nd degree certificate of the Russian agro-industrial exhibition “Gold Autumn” for the high-quality development of equipment and devices for fulfilling the supervisory roles by the State Technical Authority agencies. 2002.

TRAINING CENTER

«RUSSIAN TECHNICAL ROAD SAFETY CENTER»

The private educational institution, the Center of Supplementary Vocational Education (increased qualification) for Specialists, the “Russian Technical Road Safety Center”, was founded in 2001 on the base of the scientific production firm “META”, thanks to which the Center possesses one of Russia’s best training and material technical bases.

The main types of activity of the Russian Technical Road Safety Center are vocational training, advanced training, improvement of experts’ skills, satisfac-



tion of experts’ requirements in receiving knowledge on the newest achievements in corresponding branches of science and technology and leading Russian and foreign experience, the organization and conducting of scientific research, scientific/technical and trial/experimental tasks, consulta-

MAIN EDUCATIONAL PROGRAMS	TRAINING PERIOD
1. VOCATIONAL ADVANCED TRAINING FOR SPECIALISTS IN AUTOTECHNICAL EXPERTISE (EXPERT-AUTOMECHANIC)	
Leaders and specialists with advanced technical education, having qualification in a related profession	2.5 months
2. ADVANCED TRAINING OF SPECIALISTS IN AUTOTECHNICAL EXPERTISE (EXPERT-AUTOMECHANIC) PROGRAM: "EVALUATION OF AUTO TRANSPORT RESOURCES"	
Leaders and specialists with advanced technical education, having the qualification "Specialist in Autotechnical Expertise (Expert-Auto Mechanic)"	2.5 weeks
3. VOCATIONAL TRAINING OF SKILLED LABOR WORKERS "INSPECTOR OF TECHNICAL CONDITION OF AUTO MOTOR TRANSPORT RESOURCES"	
People with qualification and work experience: mechanics for the repairing of automobiles or more advanced qualification in a related profession, drivers of transportation in the categories "B" and "C"	1 month
4. COURSE OF ADVANCED TRAINING FOR INSPECTORS OF TECHNICAL CONDITION OF AUTO MOTOR TRANSPORT RESOURCES PROGRAM: "HEAD OF TECHNICAL INSPECTION STATION"	
People with the qualification "Inspector of Technical Condition of Auto Motor Transport Resources"	1 week
5. COURSE OF VOCATIONAL ADVANCED TRAINING OF SKILLED LABOR WORKERS "EXPERT-TECHNICIAN OF TECHNICAL CONDITION OF TRANSPORT RESOURCES"	
People, specialists with advanced or technical education, having qualification and work experience: mechanics for the repairing of automobiles, drivers of transportation in the categories "B" and "C"	2.5 weeks
6. COURSE OF VOCATIONAL ADVANCED TRAINING OF SKILLED LABOR WORKERS "INSPECTOR-OPERATOR OF WEIGHT CHECK OF TRANSPORT RESOURCES"	
	1 week
7. COURSE OF VOCATIONAL ADVANCED TRAINING OF SPECIALISTS "SPECIALIST OF SERVICE DEPARTMENT"	
	1 week

tion activity, and scientific evaluation of programs, projects, recommendations, and other materials in the area of monitoring the technical condition of vehicles.

In the 11 years of the Center's operation, training has taken place for more than 10,000 specialists for work at government technical inspection stations, experts in vehicle technical condition, and specialists providing solutions for the general issue of road safety.

At the center a qualified and consistent pedagogical team has been assembled, which possesses

great potential and an ability to resolve modern issues in the training of specialists. The students have at their disposal progressive training technology, new software packages, and comfortable auditoriums equipped with the newest equipment. The students in the courses have a unique opportunity to gain practical work skills directly on the equipment issued by the scientific production firm "META".

The updating and expansion of the center's educational programs are taking place with consideration for the development of the branch and are directed at meeting the growing needs of the customer. The programs implemented at the center are relevant and in demand on the educational service market.

The base level of education of graduates accepted for training is intermediate or advanced vocational education, depending on the chosen program.

The form of training for the students is on-site or on-site/off-site with the use of modern distance training technology.

At this time the Ministry of Education and Science has licensed more than twenty of the Center's additional vocational education programs.

All educational programs are developed by teachers at the center, taking into account the modern level of development of specific branches of industry and business needs, new achievements in science and technology, and information and communication technologies.

The contents of the educational programs meet the principle of sequence and system approach in the training of specialists. The customer's proposals and their individual concerns are taken into account, and the combination of theoretical and practical lessons are a mandatory condition.

At the classes, the student receives not only professional knowledge but also



practical experience. He/she has the opportunity to receive a qualified consultation with specialists on issues that arise outside the educational program, exchange experience with his/her colleagues from different regions, and establish business relationships with new partners.

Both an independent specialist (individual or in a group) and an entire team of businesses

can receive supplementary vocational education. Today, corporate education is not simply a fashionable trend, but a real investment into the future company, a pledge of stable work for the business.

The center conducts thematic and topical seminars in scientific/technical, technological, socioeconomic and other topics that arise at the level of the branch, region, or organization.

One of the areas of activity of the Russian Technical Road Safety Center is consultation, conducted according to the following focuses:

- construction of state technical inspection stations and technical inspection points;
- use of diagnostic equipment in the examination of the technical condition of transportation resources;
- technologies and software and hardware packages for monitoring the technical condition of transportation resources for compliance with safety requirements;
- maintenance of diagnostic equipment.

Supplementary vocational education is the road to success.



Private Educational Institution, Center of Supplementary Vocational Education for Specialists, "Russian Technical Road Safety Center"

Tel. 937-217-75-75

Tel/Fax (84862) 2-53-91

rtcbdd@rtcbdd.ru

abcd753@yandex.ru

<http://www.rtcbdd.ru/>

<http://www.meta-ru.ru/>

Director

Vladimir Vasilyevich Martynov

SERVICE CENTERS

CITY, NAME OF ORGANIZATION	CONTACT TELEPHONE NUMBERS	SERVICE	DEALER
Moscow, OOO SPC "META"	(499) 784-41-15, 784-41-16	+	+
Arkhangelsk, OOO "GARO-SERVIS"	(8182) 29-3382, 470-420		+
Almaty, TOO "Kompaniya ECOS"	(3272) 50-71-91, 61-19-58, 61-19-29		+
Anapa, OOO "Techauto"	(86133) 2-10-83		+
Barnaul, AKOD "Ekopribor"	(3852) 63-38-01, 63-38-42		+
Barnaul, OOO "GARO-SERVIS"	(3852) 31-93-77, 69-23-13, 69-50-64		+
Blagoveshchensk, OOO "Farm-Express"	(3852) 35-68-04, 35-67-65		+
Bryansk, OOO "Technovek"	(4832) 51-67-67, 29-66-25	+	+
Veliky Novgorod, GARO-TRADE	(8182) 196931,		+
Vologda, OOO "AUTOSERVISKOMPLEKT"	(8172) 74-78-89		+
Volgograd, Volgograd district department VOA	(8442) 28-96-60, 28-96-58	+	+
Volgograd, IP Kuznetsova E.V.	(8442) 36-84-63, 28-96-58		+
Vladivostok, OOO "TECHNOTEST"	(4232) 26-12-12, 228-753	+	+
Vladikavkaz, RTS BDD SOO "AlRos+"	(8672) 53-03-94ф, 44-24-17	+	+
Georgievsk, MP "GEOEK"	(87951) 6-00-53, 6-13-30		
Ekaterinburg, OOO "SERVISNY CENTER Ormet"	(343) 216-96-36, 331-99-87, 228-37-83	+	+
Ekaterinburg, ZAO "S.AUTO.-Oborudovaniye"	(343) 339-09-41, 370-21-97		+
Ekaterinburg, MO "Otdel Meditsinsky Tekhniki"	(343) 231-80-00, 231-80-10		+
Ekaterinburg, GUC SO POP "Medtehnika"	(343) 341-02-43, 341-05-90, 341-02-40		+
Ivanovo, OOO "CHEKA"	(4932) 49-17-29, 34-40-20	+	+
Izhevsk, OOO "Techkontrol"	(3412) 50-70-47, 50-66-24, 50-50-84		+
Irkutsk, OOO "TS DA"	(3952) 44-59-74, 44-59-55, 44-61-35	+	+
Kazan, OOO "TechnorosT"	(843) 570-63-73, 570-63-66	+	+
Kazan, OOO "TechnorosT"	(843) 275-83-10, 229-88-72		+
Kaliningrad, OOO "Profinstrument"	(4012) 65-00-61		+
Kaliningrad, Meta-Kaliningrad	(4012) 76-45-48		+
Kemerovo, OOO "Balans-Plus"	(3842) 53-98-95, 36-65-12		+
Kiev, OOO "SKIFLTD"	+38 (044) 456-38-74, 483-35-31	+	+
Kiev, Signal 2000	+38 (044) 221-02-50, 507-26-00		+
Kishinev, Firma "BERUF AUTO"	+373 (22) 888-159, 888-158		+
Krasnodar, OOO "TS BDD"	(8612) 263-02-15	+	+
Krasnoyarsk, OOO "EMAN"	(391) 233-98-66, 233-98-69	+	+
Krasnoyarsk, OOO "Automarket"	(3912) 291-18-87	+	+
Kursk, OOO "VVP-Servis"	(47122) 4-15-63		+
Kursk, FGU "Kursky SCM"	(47122) 53-67-74	+	+
Lipetsk, Automechanic	(4742) 41-39-65, 41-06--85		+
Lvov, CP "Zapadpribor"	+38-050-370-90-07, +38-032-243-09-31		
Magnitogorsk, OOO "Podemnik"	(3519) 24-54-08, 24-90-75	+	+
Maloyaroslavets Kaluzhskaya district, MOPAZ	(48431) 2-68-90		+
Minsk, OOO "Evromechanika"	+375(17) 235-32-33		+
Minsk, MOP VTI	+375(17) 203-30-09		+
Minsk, UP "RENITS"	+375(17) 232-60-74		+
Minsk, OOO "Belovol"	+375(17) 284-19-59, 284-20-65		+
Minsk, Ekotekhnoservis	+375(17) 262-90-99	+	+
Moscow, GARO	(495) 258-81-36/37/38/22		
Moscow, ZAO Grantek-m	(495) 700-71-02 700-71-04		+
Moscow, Transtechservis	(495) 744-0624, 350-0170		+
Moscow, Arteg	(495) 287-48-04		+

Moscow, Spetsdrevtehnika	(499) 265-56-79, 261-22-78		+
Moscow, NPS "Sant"	(499) 241-61-49, ф.241-96-64		+
Moscow, US Besopasnost	(495) 368-01-80		+
Moscow, Remgaro	(499) 618-09-1		+
Moscow, ООО "Trans DK"	(495) 4966688, ф.4969383		+
Moscow, TechServisSnab			
Moscow, Fors	(495) 709-88-03, 709-86-67		+
Naberezhnye Chelny, ООО "EKOSTANDART"	(8552) 58-71-83		+
Novosibirsk, ZAO "Mera"	(283) 230-3001, 230-3002		+
Nizhny Novgorod, Autodomservis	(831) 432-57-11, 432-57-23		+
Nizhny Novgorod, Autotechstandart	(831) 438-43-21, 438-45-98		+
Nizhny Novgorod, ООО "EKARS"	(8312) 77-68-00, 77-98-86		+
Nizhny Novgorod, ООО "TESA"	(831) 413-55-44, 293-66-07		+
Nizhny Novgorod, ООО "TFK Medtehnika"	(831) 245-77-08, 240-30-91		+
Orel, ООО "Orlovsky TS BDD"	(4862) 76-39-42		+
Orenburg, ООО "Orenburgsky TS BDD"	(3532) 77-10-60		+
Orenburg, GUP OPTF "Medtehnika" (3532)	52-15-65, 52-06-89		+
Omsk, ООО PKF "Autoformat B"	(3812)46-78-88, 90-71-57, 90-84-63		
Omsk, ООО NPO "Kompaniya SIVIK"	(3812) 55-33-37, 58-56-76		+
Omsk, ООО PKF "OMAS"	(3812) 53-85-52, 57-71-80		+
Perm, ООО PTI "PermAutoTech"	(3422)60-26-60, 60-25-73		+
Omsk, ООО PKF "EKA"	(3422) 68-11-55		+
Pskov, FGU "Pskovsky SCM"	(8112)16-36-51, 16-80-24		+
Rostov-on-Don, ООО "Meta-Holding"	(863) 255-22-32		+
Samara, ООО "META-SERVIS Plus"	(846) 932-49-78, 932-49-77		+
Samara, ООО "Technostil"	(846) 268-10-86, 269-95-00		+
Saint Petersburg, "STORM-Rempribor"	(812) 552-23-03, 552-84-40		+
Saint Petersburg, Promkhimservis	(812) 702-19-99		+
Saint Petersburg, ZAO "Koncertn Promsnabkomplekt"	(812) 3278601, 5161341, 5160956		+
Saint Petersburg, "Atlet-SPB"	(812) 448-12-26		+
Saratov, ООО "RSI I K"	(8452) 35-00-53		+
Sochi, ООО "Veteran MVD"	(8622) 40-25-60, 45-14-26		+
Stavropol, ООО "Stavropolsky TS BDD"	(8652) 56-28-16, 56-43-82		+
Sterlitamak, CP Kanaev K.D.	(3473) 21-18-73		+
Surgut, ООО "Techno-group"	(346) 250-12-80, 250-04-21		+
Tashkent, ООО "META AUTOTRANSDIAGNOSTIK"	10 998 71 232-06-85		+
Togliatti, OAO "Lada Spetsoborudovaniye"	(8482) 63-82-28, 63-83-25, 63-83-18		+
Togliatti, NTS "META"	(8482) 37-64-65		+
Tumen, ООО "MB Autoride"	(3452) 34-27-22, 34-27-21, 43-47-81		+
Tumen, ООО "Priborservis"	(3452) 63-79-00, 69-54-84, 34-65-80		+
Tver, ООО "Meta-Servis"	(4822) 34-45-51		+
Ulyanovsk, ООО "Autoline-profi"	(8422) 46-07-07		+
Ufa, ООО PKP "Devona"	(3472) 77-78-00, 77-78-63		+
Ufa, ООО NPC "MEDTECHFARM"	(3472) 28-55-72, 53-61-22		+
Kabarovsk, ООО "Khabautofinservis"	(4212) 21-88-29, 23-27-68		+
Chelyabinsk, IP Kubaytsev I.V.	(351) 791-74-65		+
Chelyabinsk, ООО "OMG"	(351) 211-29-34, 211-29-49		+
Chelyabinsk, ООО "TS BDD"	(3852) 34-63-88, 34-47-05		+
Cheboksary, ООО "Elektronnyy systemy bezopasnosti"	(3852) 40-40-90, 67-66-17		+
Cheboksary, ООО "SLUZHBА SERVISNOVO OBSLUZHIVANIYA"	(8352) 51-41-91		+
Yaroslavl, ZAO "Magistral-Kontrol"	(4852) 58-01-78, 58-66-36		+
Yaroslavl, Techauto	(4852) 74-77-11		+



SCIENTIFIC-PRODUCTION COMPANY "META"

445359 Zhigulevsk,
Morkvashinskaya st., 55A
Tel/Fax (84862)2-18-55, 2-39-48, 2-10-70
www.meta-ru.ru
E-mail: marketing@meta-ru.ru

109391 Moscow,
Orekhovo-Zuevsky Proezd, 10
Tel/Fax (499)784-41-15, 784-41-16
www.meta-moscow.ru
E-mail: msk@meta-ru.ru